

**BOARD OF SUPERVISORS OF
THE TOWNSHIP OF DERRY
DAUPHIN COUNTY, PENNSYLVANIA**

ORDINANCE NO. 2023-08

**AN ORDINANCE AMENDING CHAPTER 174 OF THE DERRY TOWNSHIP CODE
OF ORDINANCES, STORMWATER MANAGEMENT, IN ITS ENTIRETY TO READ
AS SET FORTH HEREIN**

WHEREAS, Derry Township has previously ordained and enacted an ordinance entitled the Township of Derry Stormwater Management Ordinance; and

WHEREAS, the Board of Supervisors of Derry Township believes that it is in the best interest of the Township and the residents of the Township to amend the Township of Derry Stormwater Management Ordinance by amending and replacing all of Chapter 174 of the Derry Township Code of Ordinances as set forth herein.

NOW, THEREFORE, BE IT ORDAINED AND ENACTED, by the Board of Supervisors of Derry Township, Dauphin County, Pennsylvania, that Chapter 174, Stormwater Management, of the Derry Township Code of Ordinances is hereby amended and replaced in its entirety as follows:

SECTION I.

Chapter 174, Stormwater Management, of the Derry Township Code of Ordinances is hereby amended and replaced in its entirety to read as follows:

Chapter 174, Stormwater Management

TABLE OF CONTENTS

ARTICLE I - GENERAL PROVISIONS	3
§ 174-1. SHORT TITLE.....	3
§ 174-2. STATEMENT OF FINDINGS.....	3
§ 174-3. PURPOSE.....	4
§ 174-4. STATUTORY AUTHORITY.....	5
§ 174-5. APPLICABILITY.....	5
§ 174-6. RESERVED.....	6
§ 174-7. RESERVED.....	6
§ 174-8. COMPATIBILITY WITH OTHER ORDINANCE REQUIREMENTS.....	6
§ 174-9. DUTY OF PERSONS ENGAGED IN THE DEVELOPMENT OF LAND.....	6
§ 174-10. ERRONEOUS PERMIT.....	6
§ 174-11. WAIVERS.....	7
ARTICLE II - DEFINITIONS	8
§ 174-12. WORD USAGE AND DEFINITIONS.....	8
ARTICLE III - STORMWATER MANAGEMENT STANDARDS	21
§ 174-13. GENERAL REQUIREMENTS.....	21
§ 174-14. EXEMPTIONS/MODIFICATIONS.....	24
§ 174-15. VOLUME CONTROLS.....	26
§ 174-16. RATE CONTROLS – SEE APPENDIX E.....	28
ARTICLE IV - E&S STANDARDS	29
§ 174-17. EROSION AND SEDIMENTATION REQUIREMENTS DURING REGULATED EARTH DISTURBANCE ACTIVITIES.....	29
§ 174-18. TOTAL MAXIMUM DAILY LOAD (TMDL) REQUIREMENTS.....	30
ARTICLE V RIPARIAN BUFFERS	31
§ 174-19. RIPARIAN BUFFERS.....	31
ARTICLE VI (RESERVED FOR FUTURE USE)	32
ARTICLE VII - DESIGN CRITERIA	33
§ 174-20. DESIGN CRITERIA FOR STORMWATER MANAGEMENT AND DRAINAGE FACILITIES.....	33
§ 174-21. CALCULATION METHODOLOGY.....	39
ARTICLE VIII – STORMWATER MANAGEMENT (SWM) SITE PLAN AND REPORT REQUIREMENTS	43
§ 174-22. GENERAL REQUIREMENTS.....	43
§ 174-23. SWM SITE PLAN AND REPORT CONTENTS.....	43
§ 174-24. SWM SITE PLAN AND REPORT SUBMISSION.....	47
§ 174-25. SWM SITE PLAN AND REPORT REVIEW.....	47
§ 174-26. MODIFICATION OF PLANS.....	48
§ 174-27. RESUBMISSION OF DISAPPROVED SWM SITE PLAN AND REPORT.....	48
§ 174-28. AUTHORIZATION TO CONSTRUCT AND TERM OF VALIDITY.....	48
§ 174-29. AS-BUILT SURVEY PLANS, COMPLETION CERTIFICATE, AND FINAL INSPECTION.....	49
ARTICLE IX - EASEMENTS	50
§ 174-30. EASEMENTS.....	50
ARTICLE X - MAINTENANCE RESPONSIBILITIES	51
§ 174-31. FINANCIAL GUARANTEE.....	51
§ 174-32. MAINTENANCE RESPONSIBILITIES.....	53
§ 174-33. MAINTENANCE AGREEMENT FOR PRIVATELY-OWNED STORMWATER FACILITIES.....	54
ARTICLE XI - INSPECTIONS	56
§ 174-34. SCHEDULE OF INSPECTIONS.....	56

§ 174-35. RIGHT-OF-ENTRY.	57
ARTICLE XII - ENFORCEMENT AND PENALTIES.....	58
§ 174-36. NOTIFICATION.	58
§ 174-37. ENFORCEMENT.	58
§ 174-38. PUBLIC NUISANCE.	58
§ 174-39. SUSPENSION AND REVOCATION.	59
§ 174-40. PENALTIES.	59
§ 174-41. APPEALS.	59
ARTICLE XIII - PROHIBITIONS.....	60
§ 174-42. PROHIBITED DISCHARGES AND CONNECTIONS.	60
§ 174-43. ROOF DRAINS AND SUMP PUMPS.	61
§ 174-42. ALTERATION OF BMPS.	61
ARTICLE XIV - FEES AND EXPENSES	62
§ 174-44. GENERAL.	62
§ 174-45. EXPENSES COVERED BY FEES.	63
§ 174-46. RECORDING OF APPROVED SWM SITE PLAN AND RELATED AGREEMENTS.	63

APPENDIX A – SAMPLE OPERATION AND MAINTENANCE AGREEMENT AND ACCESS EASEMENT

APPENDIX B – RESERVED

APPENDIX C – STORMWATER MANAGEMENT DESIGN CRITERIA

APPENDIX D – STANDARD DETAILS

APPENDIX E – SPRING CREEK WATERSHED RELEASE RATES

APPENDIX F – STANDARD STORMWATER BMP NOTES

APPENDIX G – STANDARD PLAN CERTIFICATIONS

Chapter 174

Stormwater Management

ARTICLE I - GENERAL PROVISIONS

§ 174-1. Short Title.

This Chapter shall be known and may be cited as the “Township of Derry Stormwater Management Ordinance.”

§ 174-2. Statement of Findings.

The Board of Supervisors of the Township of Derry finds that:

- A. Stormwater is an important water resource which provides groundwater recharge for water supplies and base flow of streams, which also protects and maintains surface water quality.
- B. Federal and State regulations require the Township of Derry and Derry Township Municipal Authority (DTMA) to implement a program of stormwater controls. DTMA is required to obtain a permit for stormwater discharges from its separate storm sewer systems under the National Pollutant Discharge Elimination System (NPDES).
- C. Inadequate management of accelerated stormwater runoff resulting from development throughout a watershed increases flood flows and velocities, contributes to erosion and sedimentation, overtaxes the carrying capacity of existing streams and storm sewers, greatly increases the cost of public facilities to convey and manage stormwater, undermines floodplain management and flood reduction efforts in upstream and downstream communities, reduces groundwater recharge, threatens public health and safety, and increases non-point source pollution of water resources.
- D. Inadequate planning and management of stormwater runoff resulting from land development and redevelopment throughout a watershed can also harm surface water resources by changing the natural hydrologic patterns; accelerating stream flows (which increase scour and erosion of streambeds and stream banks thereby elevating sedimentation); destroying aquatic habitat; and elevating aquatic pollutant concentrations and loadings such as sediments, nutrients, heavy metals, and pathogens. Groundwater resources are also impacted through loss of recharge.
- E. A comprehensive program of stormwater management, including reasonable regulation of development and activities causing accelerated runoff, is fundamental to the public health, safety, welfare, and the protection of the people of the Township of Derry, ratepayers of DTMA, and all the people of the Commonwealth, their resources, and the environment.

- F. Non-stormwater discharges to Township and/or DTMA separate storm sewer systems can contribute to pollution of Waters of the Commonwealth.
- G. Public education on the control of pollution from stormwater is an essential component in successfully addressing stormwater issues.
- H. The use of green infrastructure and low impact development (LID) are intended to address the root cause of water quality impairment by using systems and practices which use or mimic natural processes to: 1) infiltrate and recharge, 2) evapotranspire, and/or 3) harvest and use precipitation near where it falls to earth. Green infrastructure practices and LID contribute to the restoration or maintenance of pre-development hydrology.
- I. For the purposes of this Ordinance, the Township is tasked with ensuring that adequate BMPs are established where and when necessary. The Township has designated DTMA to manage such post-construction stormwater BMPs when they are established.

§ 174-3. Purpose.

The purpose of this Chapter is to promote health, safety, and welfare within the Township of Derry, Dauphin County, by minimizing the harms and maximizing the benefits described in §174-2 of this Chapter through provisions intended to:

- A. Meet legal water quality requirements under State law, including regulations at 25 PA Code Chapter 93 to protect, maintain, reclaim, and restore the existing and designated uses of the Waters of the Commonwealth.
- B. Manage accelerated runoff and erosion and sedimentation problems close to their source, reduce runoff volumes and mimic predevelopment hydrology, by regulating activities that cause these problems.
- C. Preserve the natural drainage systems to the maximum extent practicable.
- D. Maintain groundwater recharge, to prevent degradation of surface and groundwater quality, and to otherwise protect water resources.
- E. Maintain existing flows and quality of streams and watercourses.
- F. Prevent scour and erosion of stream banks and streambeds.
- G. Preserve and restore the flood-carrying capacity of streams.
- H. Manage stormwater impacts close to the runoff source, with a minimum of structures and a maximum use of natural processes.
- I. Provide procedures, performance standards, and design criteria for stormwater planning and management.

- J. Provide for continual proper operation and maintenance of all temporary and permanent stormwater management facilities and Best Management Practices (BMPs) that are constructed and implemented.
- K. Provide standards to meet the NPDES permit requirements.
- L. Implement an “illegal discharge detection and elimination program” within MS4 permitted urbanized areas to address non-stormwater discharges into the Township of Derry or the Township of Derry’s/DTMA’s separate storm sewer system.

§ 174-4. Statutory Authority.

A. Primary Authority:

The Township of Derry Board of Supervisors is empowered to regulate these activities by the authority of the Act of October 4, 1978, 32 P.S., P.L. 864 (Act 167), 32 P.S. Section 680.1 et seq., as amended, the "Storm Water Management Act", and the Second Class Township Code.

B. Secondary Authority:

The Township of Derry Board of Supervisors also is empowered to regulate land use activities that affect runoff by the authority of the Act of July 31, 1968, P.L. 805, No. 247, The Pennsylvania Municipalities Planning Code, as amended.

C. DTMA Authority

The Derry Township Municipal Authority is empowered to own, operate, and maintain the Storm Water System by the authority of DTMA Resolution 2017-11, adopted February 27, 2017, the Asset Transfer Agreement, dated February 28, 2017, and the Pennsylvania Municipality Authorities Act (53 Pa. C.S.A. Ch. 56).

§ 174-5. Applicability.

- A. This Chapter shall apply to all areas of the Township of Derry, any Regulated Activity within the Township of Derry, and all stormwater runoff entering into the Derry Township separate storm sewer system from lands within the boundaries of the Township of Derry.
- B. Earth disturbance activities and associated stormwater management controls are also regulated under existing State law and implementing regulations. This Chapter shall operate in coordination with those parallel requirements; the requirements of this Chapter shall be no less restrictive in meeting the purposes of this Chapter than State law.
- C. "Regulated Activities" are any earth disturbance activities or any activities that involve the alteration or development of land in a manner that may affect stormwater runoff. “Regulated Activities” include, but are not limited to, the following listed items:

- (1) Earth Disturbance Activities.
- (2) Land Development.
- (3) Subdivision.
- (4) Construction of new or additional impervious or semi-pervious surfaces.
- (5) Construction of new buildings or additions to existing buildings.
- (6) Diversion or piping of any natural or man-made stream channel.
- (7) Installation of stormwater management facilities or appurtenances thereto.
- (8) Installation, repair, or modification of stormwater BMPs.

§ 174-6. Reserved.

§ 174-7. Reserved.

§ 174-8. Compatibility with Other Ordinance Requirements.

Approvals issued and actions taken pursuant to this Chapter do not relieve the Applicant of the responsibility to comply with or to secure required permits or approvals for activities regulated by any other applicable codes, laws, rules, statutes, or ordinances. To the extent that this Chapter imposes more rigorous or stringent requirements for stormwater management, the specific requirements contained in this Chapter shall be followed.

§ 174-9. Duty of Persons Engaged in the Development of Land.

Notwithstanding any provision(s) of this Chapter, including exemptions, any landowner or any person engaged in the alteration or development of land which may affect stormwater runoff characteristics shall implement such measures as are reasonably necessary to promote the health, safety, and welfare of others; and to prevent damage to other property. Such measures also shall include actions as are required to manage the rate, volume, direction, and quality of resulting stormwater runoff in a manner which otherwise adequately protects health, property, and water quality.

§ 174-10. Erroneous Permit.

Any permit or authorization issued or approved based on false, misleading, or erroneous information provided by an Applicant is void without the necessity of any proceedings for revocation. Any work undertaken or use established pursuant to such permit or other authorization is unlawful. No action may be taken by a board, agency or employee of the Township purporting to validate such a violation.

§ 174-11. Waivers.

- A. If the Township determines that any requirement under this Ordinance cannot be achieved for a particular regulated activity, the Township may, after an evaluation of alternatives, approve measures other than those in this Ordinance, subject to §174-14, Paragraphs B and C.
- B. Waivers or modifications of the requirements of this Ordinance may be approved by the Township if enforcement will exact undue hardship because of peculiar conditions pertaining to the land in question, provided that the modifications will not be contrary to the public interest and that the purpose of the Ordinance is preserved. Cost or financial burden shall not be considered a hardship. Modification may be considered if an alternative standard or approach will provide equal or better achievement of the purpose of the Ordinance. A request for modifications shall be in writing and accompany the Stormwater Management Site Plan submission. The request shall provide the facts on which the request is based, the provision(s) of the Ordinance involved and the proposed modification.
- C. No waiver or modification of any regulated stormwater activity involving earth disturbance greater than or equal to one acre may be granted by the Township unless that action is approved in advance by the Pennsylvania Department of Environmental Protection (DEP) or the delegated county conservation district.

ARTICLE II - DEFINITIONS

§ 174-12. Word Usage and Definitions.

For the purpose of this Chapter, certain terms and words used herein shall be interpreted as follows:

- A. Words used in the present tense include the future tense; the singular number includes the plural and the plural number includes the singular; words of masculine gender include feminine gender and non-binary genders.
- B. The word "includes" or "including" shall not limit the term to the specific example but is intended to extend its meaning to all other instances of like kind and character.
- C. The word "Lot" includes the words "Tract", and "Parcel".
- D. The word "person" includes an individual, firm, association, organization, partnership, trust, company, corporation, or any other similar entity.
- E. The words "shall", "will", and "must" are mandatory; the words "may" and "should" are permissive.
- F. The words "used or occupied" include the words "intended, designed, maintained, or arranged to be used, occupied or maintained".
- G. The time within which any act required by this Ordinance is to be performed, shall be computed by excluding the first day and including the last day. However, if the last day is a Saturday or Sunday or a holiday declared by the United States Congress or the Pennsylvania General Assembly, it shall also be excluded. The word "day" shall mean a calendar day, unless otherwise indicated.
- H. References to officially adopted regulations, standards, or publications of PADEP or other governmental agencies shall include the regulation, publication, or standard in effect on the date when a SWM Site Plan is first filed. It is the intent of the Board of Supervisors in enacting this Section to incorporate such changes to statutes, regulations, and publications to the extent authorized by 1 Pa. C.S. §1937.
- I. Any words not defined in this Chapter or in Section 107 of the MPC shall be construed as defined in standard dictionary usage; however, if a term is undefined by this Chapter, but is defined in Chapter 185 (Subdivision and Land Development), then the definition of the term in Chapter 185 shall also apply to the term used in this Chapter.

Accelerated Erosion - The removal of the surface of the land through the combined action of human activity and natural processes at a rate greater than would occur because of the natural process alone.

Agricultural Activity - Activity associated with agriculture such as agricultural cultivation, agricultural operation, and animal-heavy use areas. This includes the work of producing crops, tillage, land clearing, plowing, disking, harrowing, planting, harvesting crops, or

pasturing and raising of livestock and installation of conservation measures. The construction of new buildings or impervious areas, filling and excavating, road maintenance, maintenance and/or construction of fixed structures involving earth disturbance activity, and the moving, depositing, stockpiling, or storing of soil, rock or earth materials shall not be included in the definition of "agricultural activity."

Alteration - As applied to land, a change in topography as a result of the moving of soil and rock from one location or position to another; changing of surface conditions by causing the surface to be more or less impervious; land disturbance.

Applicant - A landowner, developer, or other person who has filed an application for approval to engage in any Regulated Activities at a project site within the Township of Derry.

Best Management Practices (BMPs) - Activities, facilities, designs, measures, or procedures used to manage stormwater impacts from Regulated Activities, to meet State Water Quality Requirements, to promote groundwater recharge, and to otherwise meet the purposes of this Chapter. Stormwater BMPs are commonly grouped into one of two broad categories or measures: *non-structural* or *structural*:

- *Non-structural BMPs* are measures referred to as operational and/or behavior-related practices that attempt to minimize the contact of pollutants with stormwater runoff.
- *Structural BMPs* are measures that consist of a physical device or practice that is installed to capture and treat stormwater runoff, and include, but are not limited to, a wide variety of practices and devices, from large-scale retention (wet) ponds and constructed wetlands, to small-scale underground treatment systems, infiltration facilities, filter strips, low impact design, bioretention, wet ponds, permeable paving, grassed swales, riparian or forested buffers, sand filters, detention basins, and manufactured devices.

BMP Manual - The Pennsylvania Stormwater Best Management Practices Manual as published by the Pennsylvania Department of Environmental Protection, Bureau of Watershed Management, document number: 363-0300-002, effective date: December 30, 2006, and as revised. Refer also to the Pennsylvania Post-Construction Stormwater Management (PCSM) Manual.

Channel Erosion - The widening, deepening, and headward cutting of small channels and waterways, due to erosion caused by moderate to large floods.

Cistern - An underground reservoir or tank used for storing rainwater.

Conservation District - The Dauphin County Conservation District (DCCD). The Dauphin County Conservation District has the authority under a delegation agreement executed with the Pennsylvania Department of Environmental Protection to administer and enforce all or a portion of the regulations promulgated under 25 PA Code Chapter 102.

Culvert - A structure with appurtenant works that carries a stream and/or stormwater runoff under or through an embankment or fill.

Dam - An artificial barrier, together with its appurtenant works, constructed for the purpose of impounding or storing water or another fluid or semifluid; or a refuse bank, fill, or structure for

highway, railroad, or other purposes which does or may impound water or another fluid or semifluid.

Derry Township Municipal Authority (DTMA) – a Pennsylvania Municipal Authority that manages Stormwater and Wastewater, organized and existing under the Pennsylvania Municipality Authorities Act, or its designee.

Design Storm - The magnitude and temporal distribution of precipitation from a storm event measured in probability of occurrence (e.g., a 25-year storm) and duration (e.g., 24 hours), used in the design and evaluation of stormwater management systems. Also see Return Period.

Designee - The agent of the Township of Derry and/or agent of the governing body involved with the administration, review, or enforcement of any provisions of this Chapter by contract or memorandum of understanding.

Detention Basin - An impoundment structure designed to manage stormwater runoff by temporarily storing the runoff and releasing it at a predetermined rate.

Detention Volume - The volume of runoff that is captured and released during or after a storm event into Waters of the Commonwealth at a controlled rate.

Developer - A person, partnership, association, corporation, or other entity, or any responsible person therein or agent thereof, that undertakes any Regulated Activity of this Chapter.

Developed Parcel – A parcel that contains impervious area equal to or greater than 500 square feet.

Development Site (Site) - The specific tract of land for which a Regulated Activity is proposed. Also see Project Site.

Disturbed Area - An unstabilized land area where an Earth Disturbance Activity is occurring or has occurred.

Downslope Property Line - That portion of the property line of the lot, tract, or parcels of land being developed located such that all overland or piped flow from the site would be directed toward it.

Drainage Conveyance Facility - A stormwater management facility designed to convey stormwater runoff including, but not limited to, streams, channels, swales, pipes, conduits, culverts, storm sewers, roads, and ditches.

Drainage Easement - A right granted by a landowner to a grantee, allowing the use of private land for stormwater management, drainage, or conveyance purposes.

Drainageway - Any natural or artificial watercourse, trench, ditch, pipe, swale, channel, or similar depression into which surface water flows.

Earth Disturbance Activity - A construction or other human activity which disturbs the surface of the land, including, but not limited to, clearing and grubbing, grading, excavations, embankments, land development, agricultural plowing or tilling, timber harvesting activities, road maintenance activities, mineral extraction, and the moving, depositing, stockpiling, or storing of soil, rock, or earth materials.

Erosion - The movement of soil particles by the action of water, wind, ice, chemical action or other forces.

Erosion and Sediment Pollution Control Plan - A plan which is designed to minimize accelerated erosion and sedimentation.

Exceptional Value Waters - Surface waters of high quality, which satisfies PA Code Title 25 Environmental Protection, Chapter 93 Water Quality Standards 93.4b(b) (relating to anti-degradation).

Existing Conditions - The dominant land cover during the 5-year period immediately preceding a proposed regulated activity. If the initial condition of the site is not forested or undeveloped land, the land use shall be considered as "meadow" unless the natural land cover is documented to generate lower curve numbers or Rational "C" Coefficients, such as forested lands.

FEMA - The Federal Emergency Management Agency.

Floodplain – For the purposes of this Chapter, any land area susceptible to inundation by water from any natural source or delineated by applicable FEMA maps and studies as being a special flood hazard area. Included are lands adjoining a river or stream that have been or may be inundated by a 100-year flood. Also included are areas that comprise Group 13 Soils, as listed in Appendix A of the Pennsylvania Department of Environmental Protection (PADEP) Technical Manual for Sewage Enforcement Officers (as amended or replaced from time to time by PADEP).

Floodway - The channel of the watercourse and those portions of the adjoining floodplains that are reasonably required to carry and discharge the 100-year flood. Unless otherwise specified, the boundary of the floodway is as indicated on maps and flood insurance studies provided by FEMA. In an area where no FEMA maps or studies have defined the boundary of the 100-year floodway, it is assumed--absent evidence to the contrary--that the floodway extends from the stream to 50 feet from the top of the bank of the stream.

Forest Management/Timber Operations - Planning and activities necessary for the management of forestland. These include timber inventory and preparation of forest management plans, silvicultural treatment, cutting budgets, logging road design and construction, timber harvesting, site preparation, and reforestation.

Freeboard - A vertical distance between the elevation of the design high water and the top of a dam, levee, tank, basin, or diversion ridge. The space is required as a safety margin in a pond or basin.

Grade - A slope, usually of a road, channel, or ground surface specified in percent and shown on plans as specified herein.

(To) Grade - To finish the surface of a roadbed, top of embankment, or bottom of excavation.

Green Infrastructure – Systems and practices that use or mimic natural processes to infiltrate, evapotranspire, or reuse stormwater on the site where it is generated.

Groundwater Recharge - Replenishment of existing natural underground water supplies.

HEC-HMS Model Calibrated - (Hydrologic Engineering Center-Hydrologic Modeling System) A computer-based hydrologic modeling technique adapted to the watersheds in Dauphin County for the Act 167 Plan. The model has been calibrated by adjusting key model input parameters.

HEC-RAS - US Army Corps of Engineers River Analysis System an integrated system of software, designed for interactive use in a multi-tasking environment. The system is comprised of a graphical user interface (GUI), separate analysis components, data storage and management capabilities, graphics, mapping and reporting facilities.

High Quality Waters - Surface water having quality, which exceeds levels necessary to support propagation of fish, shellfish, and wildlife and recreation in and on the water by satisfying PA Code Title 25 Environmental Protection, Chapter 93 Water Quality Standards 93.4b(a).

Hydrologic Soil Group (HSG) - Infiltration rates of soils vary widely and are affected by subsurface permeability as well as surface intake rates. Soils are classified into one of four HSGs (A, B, C, and D) according to their minimum infiltration rate, which is obtained for bare soil after prolonged wetting. The Natural Resource Conservation Service (NRCS) of the U.S. Department of Agriculture defines the four groups and provides a list of most of the soils in the United States and their group classification. The soils in the area of interest may be identified from a soil survey report from the local NRCS office or the DCCD. Soils become less pervious as the HSG varies from A to D (NRCS^{1 2}).

Impervious Cover (a.k.a. Impervious Surface and Impervious Area) - A surface of a lot that has been compacted or covered with material to the extent that it is highly resistant to infiltration by water. Impervious cover (surfaces or areas) shall include, but is not limited to: conventional impervious surfaces such as paved streets, roofs, compacted stone, and sidewalks. Impervious cover shall consist of the following surfaces when used by motor vehicles or pedestrians: graveled areas, paver blocks (including voids), bricks, and cobblestone. The water area of swimming pools shall not be considered to be impervious surfaces if the overflow system of the pool is connected to a sanitary sewer system. Decks are not counted as impervious areas if they do not prevent infiltration. Any surface areas

¹ U.S. Department of Agriculture, National Resources Conservation Service (NRCS). *National Engineering Handbook*. Part 630: Hydrology, 1969-2001. Originally published as the *National Engineering Handbook*, Section 4: Hydrology. Available from the NRCS online at: <http://www.nrcs.usda.gov/>.

² U.S. Department of Agriculture, Natural Resources Conservation Service. 1986. *Technical Release 55: Urban Hydrology for Small Watersheds*, 2nd Edition. Washington, D.C.

consisting of gravel, crushed stone, or other porous material shall be assumed to be impervious, unless designed, approved, and maintained as an infiltration BMP.

Infiltrate – To permeate water into the ground.

Infiltration BMP – Any Best Management Practice stormwater facility designed, approved, and maintained or used to direct runoff into the ground.

Infiltration Structures - A structure designed to direct runoff into the ground (e.g., French drains, seepage pits, seepage trench, etc.).

Inlet - A surface connection to a closed drain; a structure at the diversion end of a conduit; and/or the upstream end of any structure through which water may flow.

Karst - A type of topography or landscape characterized by surface depressions, sinkholes, rock pinnacles/uneven bedrock surface, steep-sided hills, underground drainage, and caves. Karst is formed on carbonate rocks, such as limestone or dolomites and sometimes gypsum.

Land Development or Development - Any of the following activities:

- (1) The improvement of one lot or two or more contiguous lots, tracts, or parcels of land for any purpose involving:
 - (a) A group of two or more residential or nonresidential buildings, whether proposed initially or cumulatively, or a single nonresidential building on a lot or lots, regardless of the number of occupants or tenure.
 - (b) The addition of 2,500 square feet of floor area to a nonresidential building or residential building, except single-family detached, two-family detached, single-family semi-detached, and single-family attached dwellings.
 - (c) The division or allocation of land or space, whether initially or cumulatively between or among two or more existing or prospective occupants by means of or for the purpose of streets, common areas, leaseholds, condominiums, buildings, groups, or other features.
- (2) A subdivision of land.

Exceptions. The following shall not be construed as land development activities:

- (1) The conversion of an existing single-family detached dwelling or single-family semi-detached dwelling into not more than three residential units, unless such units are intended to be a condominium.
- (2) The addition of an accessory building, including farm buildings, on a lot of an existing principal building.
- (3) The conversion of buildings or rides within the confines of an enterprise which would be considered an amusement park. For the purposes of this subsection, an

amusement park is defined as a tract or area used principally as a location for permanent amusement structures or rides. This exclusion shall not apply to newly acquired acreage by an amusement park until initial plans for the expanded area have been approved by the Township.

Legacy Sediment – Any soil that has been eroded from upland areas after the arrival of early settlers and over centuries of intensive land uses which has altered the natural course or integrity of the stream and/or floodplains.

Limit of Disturbance - A line provided on the SWM Site Plan that indicates the total area to be disturbed during a proposed earth disturbance activity.

Low Impact Development (LID) – Site design approaches and small-scale stormwater management practices that promote the use of natural systems for infiltration, evapotranspiration, and reuse of rainwater. LID can be applied to new development, urban retrofits, and revitalization projects. LID utilizes design techniques that infiltrate, filter, evaporate, and store runoff close to its source. Rather than rely on costly large-scale conveyance and treatment systems, LID addresses stormwater through a variety of small, cost-effective landscape features located on-site.

Main Stem (Main Channel) - Any stream segment or other runoff conveyance facility used as a reach in the Dauphin County Act 167 watershed hydrologic model(s).

Manning's Equation (Manning's Formula) - A method for calculation of velocity of flow (e.g., feet per second) and flow rate (e.g., cubic feet per second) in open channels based upon channel shape, roughness, depth of flow, and slope. "Open channels" may include closed conduits so long as the flow is not under pressure.

Municipal Separate Storm Sewer System (MS4) - a conveyance or system of conveyances that is:

- (1) Owned by a state, city, town, village, or other public entity that discharges to waters of the Commonwealth;
- (2) Designed or used to collect or convey stormwater (including storm drains, pipes, ditches, etc.);
- (3) Not a combined sewer; and,
- (4) Not part of a Publicly Owned Treatment Works (sewage treatment plant).

National Pollutant Discharge Elimination System (NPDES) - The federal government's system for issuance of permits under the Clean Water Act, which is delegated to PADEP in Pennsylvania. The federal government's and Commonwealth of Pennsylvania's system for issuance of discharge permits under the federal Clean Water Act (CWA), the Pennsylvania Clean Streams Law and Storm Water Management Act. The Pennsylvania Department of Environmental Protection (PADEP) has been delegated the responsibility to implement the federal CWA NPDES program in Pennsylvania.

NOAA Atlas 14 - Precipitation-Frequency Atlas of the United States, Atlas 14, U.S. Department of Commerce, National Oceanic and Atmospheric Administration, National Weather Service, Hydrometeorological Design Studies Center, Silver Spring, Maryland, latest edition.

Non-Point Source Pollution - Pollution that enters a water body from diffuse origins in the watershed and does not result from discernible, confined, or discrete conveyances.

NRCS - Natural Resource Conservation Service (previously Soil Conservation Service (SCS)).

Open Channel - A drainage element in which stormwater flows with an open surface. Open channels include, but shall not be limited to, natural and man-made drainageways, swales, streams, ditches, canals, and pipes not under pressure.

Operation and Maintenance - The associated costs of equipment and facilities, energy, manpower, materials, transportation, and services required to collect, convey, detain, pump and transport stormwater, keep equipment, infrastructure, and facilities functioning satisfactorily and economically, administer the Stormwater Management Program and shall include sums paid to defray costs of the Authority's improvements to the Stormwater Management System.

O&M Agreement – See “Stormwater Operation and Maintenance Agreement and Access Easement”

Outfall - (i) The point where water flows from a conduit, stream, or drain; (ii) “Point Source” as described in 40 CFR §122.2, the point where the storm sewer system within the Township discharges to surface Waters of the Commonwealth.

Outlet - Points of water disposal from a stream, river, lake, tidewater, or artificial drain.

Owner – Any person, firm, corporation, individual, partnership, trust, company, association, government agency, society or group owning real property in the Township of Derry.

PADEP - The Pennsylvania Department of Environmental Protection.

Pennsylvania Post-Construction Stormwater (PCSM) Manual - The most recent version of the Pennsylvania Post-Construction Stormwater Manual (document no. 386-0300-001).

Parking Lot Storage - The use of impervious parking areas as temporary impoundments with controlled release rates during rainstorms.

Peak Discharge - The maximum rate of stormwater runoff from a specific storm event.

Person - An individual, partnership, public or private association or corporation; or a governmental unit, public utility, or any other legal entity whatsoever which is recognized by law as the subject of rights and duties.

Pervious Area - Any area not defined as impervious.

Pipe - A culvert, closed conduit, or similar structure (including appurtenances) that conveys stormwater.

Planning Commission - The Planning Commission of the Township of Derry.

Point Source - Any discernible, confined, or discrete conveyance, including, but not limited to: any pipe, ditch, channel, tunnel, or conduit from which stormwater is or may be discharged, as defined in State regulations at 25 Pennsylvania Code §92.1.

Probable Maximum Flood (PMF) - The flood that may be expected from the most severe combination of critical meteorological and hydrologic conditions that are reasonably possible in any area. The PMF is derived from the probable maximum precipitation (PMP) as determined on the basis of data obtained from the National Oceanographic and Atmospheric Administration (NOAA).

Project Site - The specific area of land where any Regulated Activities in the Township are planned, conducted, or maintained.

Property – Each lot, parcel, building or portion thereof, which may be separately established by Uniform Parcel Identifier on the tax rolls of Derry Township or Dauphin County

Qualified Professional - Any person licensed by the Pennsylvania Department of State or otherwise qualified by law to perform the work required by this Chapter.

Rational Formula - A rainfall-runoff relation used to estimate peak flow.

Redevelopment - Earth disturbance activities on land which has previously been developed.

Regulated Activities - Any earth disturbance activities or any activities that involve the alteration or development of land in a manner that may affect stormwater runoff.

Regulated Earth Disturbance Activity - Activity involving earth disturbance subject to regulation under 25 PA Code Chapter 92, Chapter 102, or the Clean Streams Law.

Release Rate - The percentage of pre-development peak rate of runoff from a site or subwatershed area to which the post-development peak rate of runoff must be reduced to protect downstream areas.

Release Rate District - Those subwatershed areas in which post-development flows must be reduced to a certain percentage of pre-development flows as required to meet the plan requirements and the goals of Act 167.

Retention Volume/Removed Runoff - The volume of runoff that is captured and not released directly into the surface Waters of the Commonwealth during or after a storm event.

Return Period - The average interval, in years, within which a storm event of a given magnitude can be expected to recur. For example, the probability of a 25-year storm occurring in any one given year is 0.04 (i.e. a 4% chance).

Riparian - Pertaining to a stream, river or other watercourse. Also, plant communities occurring in association with any spring, lake, river, stream, or creek through which waters flow at least periodically.

Riparian Buffer - A vegetated area bordering perennial and intermittent streams and wetlands that serves as a protective filter to help protect streams and wetlands from the impacts of adjacent land uses.

Riser - A vertical pipe extending from the bottom of a pond that is used to control the discharge rate from the pond for a specified design storm.

Road Maintenance - Earth disturbance activities within the existing road right-of-way, such as grading and repairing existing unpaved road surfaces, cutting road banks, cleaning or clearing drainage ditches, and other similar activities. Road maintenance activities that do not disturb the subbase of a paved road such as milling and pavement overlays are not considered earth disturbance activities.

Rooftop Detention - Temporary ponding and gradual release of stormwater falling directly onto flat roof surfaces by incorporating controlled-flow roof drains into building designs.

Runoff - Any part of precipitation that flows over the land surface.

Runoff Capture Volume - The volume of runoff that is captured (retained) and not released into surface Waters of the Commonwealth during or after a storm event.

Sediment - Soils or other materials transported by surface water as a product of erosion.

Sediment Basin - A barrier, dam, or detention basin located and designed to retain rock, sand, gravel, silt, or other material transported by stormwater runoff.

Sediment Pollution - The placement, discharge, or any other introduction of sediment into Waters of the Commonwealth occurring from the failure to properly design, construct, implement, or maintain control measures and control facilities in accordance with the requirements of this Chapter.

Sedimentation - The process by which mineral or organic matter is accumulated or deposited by the movement of water.

Seepage Pit/Seepage Trench - An area of excavated earth filled with loose stone or similar coarse material into which surface water is directed for infiltration into the ground.

Sensitive Environmental Areas - Sensitive environmental areas shall consist of the following:

- (1) Land areas having slopes in excess of 20% which are not the result of man-made changes to the natural terrain.
- (2) Wetlands.

- (3) Areas of quarries, streams, lakes, dams, or ponds and all areas within 50 feet of such features.
- (4) Cemeteries and all areas within 50 feet of a cemetery.
- (5) Landfills and areas within 50 feet of a landfill.

Separate Storm Sewer System - A conveyance or system of conveyances (including roads with or without drainage conveyance facilities, catch basins, curbs, gutters, ditches, man-made channels, or storm drains) primarily used for collecting and conveying stormwater runoff.

Sheet Flow - Runoff that flows over the ground surface as a thin, even layer, not concentrated in a channel.

Soil Cover Complex Method - A method of runoff computation developed by the NRCS that is based on relating soil type and land use/cover to a runoff parameter called curve number (CN).

SPECIAL FLOOD HAZARD AREA - An area in the floodplain subject to a one-percent or greater chance of flooding in any given year. It is shown on the FIRM as Zone A, AO, A1-30, AE, A99, or AH.

Spillway (Emergency) - A depression in the embankment of a pond or basin, or other overflow structure, that is used to pass peak discharges greater than the maximum design storm controlled by the pond or basin.

State Water Quality Requirements - The regulatory requirements to protect, maintain, reclaim, and restore water quality under Title 25 of the Pennsylvania Code and the Clean Streams Law.

Storage Indication Method - A reservoir routing procedure based on solution of the continuity equation (inflow minus outflow equals the change in storage) with outflow defined as a function of storage volume and depth.

Storm Event - A storm of a specific duration, intensity, and frequency.

Storm Frequency - The number of times that a given storm event occurs or is exceeded on the average in a stated period of years. See also "Return Period".

Storm Sewer - A system of pipes and/or open channels that convey intercepted runoff and stormwater from other sources but excludes domestic sewage and industrial wastes.

Stormwater - Drainage runoff from the surface of the land resulting from precipitation; or snow or ice melt. Water from a precipitation event that flows across the land and eventually into rivers, creeks, lakes, ditches, and canals resulting in debris, sediment, pollutants, bacteria, and nutrients from sidewalks, streets, parking lots, and other impervious areas washing into gutters, through storm drains, and eventually flowing into the creeks and rivers.

Stormwater Management Facilities - Any structure, natural or man-made, that, due to its condition, design, or construction conveys, stores, or otherwise affects stormwater runoff. Typical stormwater management facilities include, but are not limited to: detention basins, wet ponds, open channels, storm sewers, pipes, roof leaders, and infiltration facilities.

Stormwater Management Plan - The Dauphin County Stormwater Management Plan for managing stormwater runoff in Dauphin County as required by the Act of October 4, 1978, P.L. 864, (Act 167) and known as the “Storm Water Management Act.”

Stormwater Management Site Plan (SWM Site Plan) - The plan prepared by the Applicant or his representative indicating how stormwater runoff will be managed at the project site in accordance with this Chapter.

Stormwater Operation and Maintenance Agreement and Access Easement (O&M Agreement) – An agreement as described in the Township’s Stormwater Management Ordinance pertaining to the access, operation and maintenance of existing stormwater management BMPs.

Stream Enclosure - A bridge, culvert, or other structure in excess of 100 feet in length upstream to downstream which encloses regulated Waters of the Commonwealth.

Subdivision - The division or re-division of a lot, tract, or parcel of land by any means into two or more lots, tracts, parcels or other divisions of land, including changes in existing lot lines for the purpose, whether immediate or future, of lease, partition by the court for distribution to heirs or devisees, transfer of ownership, or building or lot development; provided, however, that the subdivision by lease of land for agricultural purposes into parcels of more than 10 acres, not involving any new street, easement of access, or any residential dwelling, shall be exempted.

Subwatershed Area - The smallest drainage unit of a watershed for which stormwater management criteria has been established in the Stormwater Management Plan.

Supervisors – The Board of Supervisors of the Township of Derry, Dauphin County, PA.

Swale - A low-lying stretch of land that gathers or carries surface water runoff.

Timber Operations - See “Forest Management”.

Time of Concentration (T_c) - The time for surface runoff to travel from the most hydraulically distant point of the watershed to a point of interest within the watershed. This time is the combined total of overland flow time and flow time in pipes or channels, if any.

Township – Township of Derry, Dauphin County, Pennsylvania, its Supervisors and municipal staff and/or designees.

USDA - The United States Department of Agriculture.

Watercourse - A channel or conveyance of surface water, such as a stream or creek, having defined bed and banks, whether natural or artificial, with perennial or intermittent flow.

Waters of the Commonwealth – Any and all Rivers, streams, creeks, rivulets, impoundments, ditches, watercourses, storm sewers, lakes, dammed water, wetlands, ponds, springs, and other bodies or channels of conveyance of surface and underground water, or parts thereof, whether natural or artificial, within or on the boundaries of the Commonwealth of Pennsylvania.

Watershed - Region or area drained by a river, watercourse, or other surface water, whether natural or artificial within or on the boundaries of this Commonwealth.

Wetland - Areas that are inundated or saturated by surface or ground water at a frequency and duration sufficient to support and, that under normal circumstances, do support, a prevalence of vegetation typically adapted for life in saturated soil conditions including swamps, marshes, bogs, and similar areas, and which may be identified as jurisdictional wetlands using methods described in the current edition of the "Federal Manual for Identifying and Delineating Jurisdictional Wetlands."

ARTICLE III - STORMWATER MANAGEMENT STANDARDS

§ 174-13. General Requirements.

- A. All Regulated Activities shall include, to the maximum extent practicable, measures to:
- (1) Protect health, safety, and property.
 - (2) Meet the water quality goals of this Chapter by implementing measures to:
 - (a) Minimize disturbance to Sensitive Environmental Areas.
 - (b) Create, maintain, or extend riparian buffers and protect existing forested buffers.
 - (c) Provide trees and woodlands adjacent to impervious areas whenever feasible.
 - (d) Minimize the creation of impervious surfaces and the degradation of Waters of the Commonwealth and promote groundwater recharge.
 - (e) Protect natural systems and processes (drainageways, vegetation, soils, and sensitive areas) and maintain, as much as possible, the natural hydrologic regime.
 - (f) Incorporate natural site elements (wetlands, stream corridors, mature forests) as design elements.
 - (g) Avoid erosive flow conditions in natural flow pathways.
 - (h) Minimize soil disturbance and soil compaction.
 - (i) Minimize thermal impacts to Waters of the Commonwealth.
 - (j) Disconnect impervious surfaces by directing runoff to pervious areas wherever possible and decentralize and manage stormwater at its source.
 - (3) Incorporate the techniques and methods described in the Pennsylvania Stormwater Best Management Practices Manual (BMP Manual) to reduce the costs of complying with the requirements of this Chapter and the State Water Quality Requirements. If methods other than green infrastructure and LID methods are proposed to achieve the volume and rate controls required under this Ordinance, the SWM Site Plan must include a detailed justification demonstrating that the use of LID and green infrastructure is not practicable.
- B. For any Regulated Activities that create new impervious area exceeding the exemption limits specified in §174-14:
- (1) Preparation and implementation of an approved SWM Site Plan is required. Regulated activities approved under the authority of Chapter 174, as adopted by Derry Township on September 14, 2004, as amended, that have not reached completion and which may otherwise lawfully be completed, shall adhere to the

requirements of that approval. Modifications of that approval involving the increase of impervious area, the alteration of stormwater control, or of the drainage patterns shall comply with this Chapter.

- (2) No Regulated Activities shall commence until the Township issues written approval of a SWM Site Plan, which demonstrates compliance with the requirements of this Chapter.
 - (3) The SWM Site Plan shall demonstrate that adequate capacity will be provided to meet the volume and rate control requirements, as described under §174-15 and §174-16 of this Chapter.
 - (4) The SWM Site Plan approved by the Township shall be on-site throughout the duration of the Regulated Activities.
- C. For all Regulated Earth Disturbance Activities, erosion and sediment control BMPs shall be designed, implemented, operated, and maintained during the Regulated Earth Disturbance Activities (e.g., during construction) to meet the purposes and requirements of this Chapter and to meet all requirements under Title 25 of the Pennsylvania Code (including, but not limited to, Chapter 102 Erosion and Sediment Control) and the Clean Streams Law. Various BMPs and their design standards are listed in the Erosion and Sediment Pollution Control Program Manual (E&S Manual), No. 363-2134-008, March 2012, as amended and updated. (Refer to §174-14.K)
- D. For all Regulated Activities, stormwater BMPs shall be designed, installed, implemented, operated, and maintained to meet the purposes and requirements of this Chapter and to meet all requirements under Title 25 of the Pennsylvania Code and the Clean Streams Law; conform to the State Water Quality Requirements; meet all requirements under the Storm Water Management Act; and any more stringent requirements as determined by the Township.
- E. The Township may, after consultation with PADEP and/or DCCD where necessary, approve measures for meeting the State Water Quality Requirements other than those in this Chapter, provided that they meet the minimum requirements of, and do not conflict with, State law including, but not limited to, the Clean Streams Law.
- F. Impervious Areas (Refer also to §174-14.K):
- (1) The measurement of impervious areas shall include all of the impervious areas in the total proposed development, even if development is to take place in stages.
 - (2) For development taking place in stages, the entire development plan must be used in determining conformance with this Chapter.
 - (3) For projects that add impervious area to a developed parcel, the new impervious area is subject to the requirements of this Chapter; and any existing impervious area that is within the new proposed limit of disturbance is also subject to the requirements of this Chapter.

- G. If existing diffused flow is proposed to be concentrated and discharged onto adjacent property, the Applicant must document that adequate downstream conveyance facilities exist to safely transport the concentrated discharge, or otherwise prove that no erosion, sedimentation, flooding, or other harm will result from the concentrated discharge. (Refer also to §174-14.K):
- (1) The Applicant must provide an executed easement for newly-concentrated flow across adjacent properties.
- H. Stormwater drainage systems shall be provided in order to permit unimpeded flow along natural watercourses, except as modified by stormwater management facilities or open channels consistent with this Chapter.
- I. Where watercourses traverse a development site, drainage easements (with a minimum width of 20 feet) shall be provided conforming to the line of such watercourses. The terms of the easement shall prohibit excavation, the placing of fill or structures, and any alterations that may adversely affect the flow of stormwater within any portion of the easement. Also, maintenance (including mowing of vegetation within the easement) may be required, except as approved by the appropriate governing authority.
- J. When it can be shown that, due to topographic conditions, natural drainageways on the site cannot adequately provide for drainage, open channels may be constructed conforming substantially to the line and grade of such natural drainageways. Work within natural drainage ways shall be subject to approval by PADEP under regulations at 25 PA Code Chapter 105 through the Joint Permit Application process, or, where deemed appropriate by PADEP, through the General Permit process.
- K. Any stormwater management facilities or any facilities that constitute water obstructions (e.g., culverts, bridges, outfalls, or stream enclosures, etc.) that are regulated by this Chapter, that will be located in or adjacent to Waters of the Commonwealth (including wetlands), shall be subject to approval by PADEP under regulations at 25 PA Code Chapter 105 through the Joint Permit Application process, or, where deemed appropriate by PADEP, the General Permit process. When there is a question whether wetlands may be involved, it is the responsibility of the Applicant or his agent to show that the land in question cannot be classified as wetlands; otherwise, approval to work in the area must be obtained from PADEP.
- L. Should any stormwater management facility require a dam safety permit under PADEP Chapter 105, the facility shall be designed in accordance with Chapter 105 and meet the regulations of Chapter 105 concerning dam safety which may be required to pass storms larger than a 100-year event.
- M. Any stormwater management facilities regulated by this Chapter that will be located on, or discharged onto, State highway rights-of-ways shall be subject to approval by the Pennsylvania Department of Transportation (PennDOT).
- N. When stormwater management facilities are proposed within 1,000 feet of a downstream municipality, the Applicant shall submit the stormwater analysis to the downstream municipal's engineer for review and comment.

- O. Minimization of impervious surfaces and infiltration of runoff through seepage beds, infiltration trenches, etc., are encouraged, where soil conditions and geology permit, to reduce the size or eliminate the need for detention facilities.
- P. Infiltration BMPs should be dispersed throughout the site, made as shallow as practicable, and located to maximize use of natural on-site infiltration features while still meeting the other requirements of this Chapter. (Refer also to §174-14.K)
- Q. The design of facilities over Karst shall include an evaluation and implementation of measures to minimize adverse effects. (Refer also to §174-14.K)

§ 174-14. Exemptions/Modifications.

- A. No exemption or modification of any regulated stormwater activity involving earth disturbance greater than or equal to one (1) acre may be granted by the Township unless that action is approved in advance by the PADEP or the DCCD.
- B. Under no circumstance shall the Applicant be exempt from implementing such measures as necessary to:
 - (1) Meet State Water Quality Standards and Requirements.
 - (2) Protect health, safety, and property.
 - (3) Meet special requirements for High Quality (HQ) and Exceptional Value (EV) watersheds.
- C. The Applicant must demonstrate that the following BMPs are being utilized to the maximum extent practicable to receive consideration for the exemptions:
 - (1) Design around and limit disturbance of Sensitive Environmental Areas, existing native vegetation, and other sensitive and special value features.
 - (2) Maintain riparian and forested buffers.
 - (3) Limit grading and maintain non-erosive flow conditions in natural flow paths.
 - (4) Maintain existing tree canopies near impervious areas.
 - (5) Minimize soil disturbance and reclaim disturbed areas with topsoil and vegetation.
 - (6) Direct runoff to pervious areas.
- D. The Applicant must demonstrate that the proposed development/additional impervious area will not adversely impact the following:
 - (1) Capacities of existing drainageways and storm sewer systems.

- (2) Velocities and erosion.
- (3) Quality of runoff if direct discharge is proposed.
- (4) Existing known problem areas.
- (5) Safe conveyance of the additional runoff.
- (6) Downstream property owners.

E. An Applicant proposing Regulated Activities, after demonstrating compliance with §174-14.B, §174-14.C, and §174-14.D, may be exempted from various requirements of this Chapter according to the following table:

New Impervious Area [Accumulative total since December 21, 2010] (square footage)	Applicant Must Submit to the Township
Up to 5% of the subject lot area ranging from a minimum of 200 to a maximum of 1,000	---
Greater than 5% of the subject lot area or between 1,001 – 5,000	Volume Controls and SWM Site Plan & Report
> 5,000	Rate Controls, Volume Controls, SWM Site Plan & SWM Report, and As-Built Plans

*Projects that reduce the overall amount of impervious area on a Project Site are not required to abide by the above table.

F. The purpose of this section is to ensure consistency of stormwater management planning between local ordinances and NPDES permitting (when required) and to ensure that the Applicant has a single and clear set of stormwater management standards to which the Applicant is subject. The Township may accept alternative stormwater management controls provided that:

- (1) The Applicant, in consultation with the Township, PADEP, and/or DCCD, establishes that meeting the requirements of the Volume Controls or Rate Controls of this Chapter is not possible or creates an undue hardship.
- (2) The alternative stormwater management controls, proposed by the Applicant, are documented to be acceptable to the Township, PADEP, and/or DCCD for NPDES requirements pertaining to post-construction stormwater management requirements.
- (3) The alternative stormwater management controls are in compliance with all other sections of this Chapter, including, but not limited to §174-13.D, §174-14.B, §174-14.C, and §174-14.D.

G. Forest management and timber operations are exempt from Rate and Volume Control requirements and SWM Site Plan preparation requirement of this Chapter provided the

activities are performed according to the requirements of 25 PA Code Chapter 102. It should be noted that temporary roadways are not exempt.

- H. Agricultural activities are exempt from the requirements of this Chapter provided the activities are performed according to the requirements of 25 PA Code Chapter 102.
- I. Linear roadway improvement projects that create additional impervious area are not exempt from the requirements of this Chapter. However, alternative stormwater management strategies may be applied at the joint approval of the Township and DCCD (if an NPDES permit is required) when site limitations (such as limited right-of-way) and constraints (as shown and provided by the Applicant), preclude the ability of the Applicant to meet the enforcement of the stormwater management standards in this Chapter. All strategies must be consistent with PADEP's regulations, including NPDES requirements.
- J. The Township may, after an Applicant has demonstrated compliance with §174-14.B, §174-14.C, and §174-14.D, grant a modification of the requirements beyond that permitted in §174-14.E of one or more provisions of this Chapter if the literal enforcement will exact undue hardship because of peculiar conditions pertaining to the land in question, provided that such modification will not be contrary to the public interest and that the purpose and intent of this Chapter are observed.
 - (1) All requests for a modification shall be in writing and listed on the SWM Site Plan Cover sheet and shall state in full the grounds and facts of unreasonableness or hardship on which the request is based, the provision or provisions of the Chapter involved, and the minimum modification or alternative design necessary to lessen the unreasonableness or hardship.
- K. Exemptions from any provisions of this Ordinance shall not relieve the applicant from the requirements in §174-13.A, C, F, G, P, and Q; § 174-20.B.(8); and §174-21.C.(2).
- L. The Township may deny or revoke any exemption pursuant to this Section at any time for any project that the Township believes may pose a threat to public health and safety or the environment and/or would otherwise be inconsistent with this Chapter.

§ 174-15. Volume Controls.

- A. Required storage volume for Volume Controls is to be calculated separately from, and in addition to, volume required for Rate Controls. Volume required to meet the Rate Controls must be calculated separately and be modeled in the proposed BMP above the required storage volume for Volume Controls.
- B. The green infrastructure and Low Impact Development Practices provided in the BMP Manual shall be utilized for all Regulated Activities to the maximum extent practicable.
- C. Stormwater runoff Volume Controls shall be implemented using the *Design Storm Method* or the *Simplified Method*. For Regulated Activities equal to or less than one (1) acre, this Chapter establishes no preference for either method; therefore, the Applicant may select either method on the basis of economic considerations, the intrinsic

limitations on applicability of the analytical procedures associated with each methodology, and other factors.

- (1) The *Design Storm Method* (CG-1 in the BMP Manual) may be used for any sized Regulated Activity. This method requires detailed modeling based on site conditions and compliance with the following:
 - (a) No increase of the post-development total runoff volume when compared to the pre-development total runoff volume for the 2-year/24-hour storm event shall be permitted.
 - (b) For hydrologic modeling purposes:
 - [1] Existing non-forested pervious areas must be considered meadow (good condition) for pre-development hydrologic calculations.
 - [2] Twenty (20) percent of existing impervious area which existed prior to December 21, 2010, when present on the proposed project site and contained within the new proposed limit of disturbance, shall be considered meadow (good condition) for pre-development hydrologic calculations for re-development.
 - (2) The *Simplified Method* (CG-2 in the BMP Manual) is independent of site conditions and should be used if the *Design Storm Method* is not followed. This method is not applicable to Regulated Activities greater than one (1) acre. For new impervious surfaces:
 - (a) Stormwater facilities shall capture at least the first two (2) inches of runoff from all new impervious surfaces.
 - (b) At least the first one (1) inch of runoff from new impervious surfaces shall be permanently removed from the runoff flow, i.e., it shall not be released into surface Waters of this Commonwealth. Removal options include reuse, evaporation, transpiration, and infiltration.
 - (c) Wherever possible, infiltration facilities should be designed to accommodate infiltration of the entire permanently removed runoff, however, in all cases at least the first half (0.5) inch of the permanently removed runoff should be infiltrated.
 - (d) If infiltration is not possible due to site conditions, CG-1 must be used.
 - (e) This method is exempt from the requirements of §174-16, Rate Controls.
- D. All applicable PADEP worksheets or the PADEP PCSM Spreadsheet must be used when establishing Volume Controls.
- E. Actual field infiltration tests at the location of the proposed elevation of the stormwater BMPs are required when 5,000 square feet or greater of new impervious surface is

added. Infiltration test shall be conducted in accordance with the BMP Manual. The Township shall be notified 24-hours prior to infiltration tests being conducted to provide an opportunity for the Township to witness the tests.

- F. Absent actual field infiltration tests witnessed by the Township or their representative, infiltration rates may not be used to design BMPs. For Volume Control storage calculations, assume no infiltration to size the BMP.

§ 174-16. Rate Controls

- A. Required storage volume for Rate Controls is to be calculated separately from, and in addition to, volume required for Volume Controls. Volume required to meet the Rate Controls must be calculated separately and be modeled in the proposed BMP above the required storage volume for Volume Controls.
- B. Lands contained within Derry Township that have not had release rates established under an approved Act 167 Stormwater Management Plan:
 - (1) Post-development discharge rates shall not exceed the pre-development discharge rates for the 1-year, 2-year, 10-year, 25-year, 50-year, and 100-year 24-hour storm events. If it is shown that the peak rates of discharge indicated by the post-development analysis are less than or equal to the peak rates of discharge indicated by the pre-development analysis for 1-, 2-, 5-, 10-, 25-, 50-, and 100-year, 24-hour storms, then the requirements of this section have been met. Otherwise, the applicant shall provide additional controls as necessary to satisfy the peak rate of discharge requirement.
- C. Lands contained within Derry Township that have had release rates established under an approved Act 167 Stormwater Management Plan (See Appendix E):
 - (1) Post-development discharge rates shall not exceed the pre-development discharge rates for the 1-year, 50-year, and 100-year storms.
 - (2) For the 2-year, 10-year, and 25-year storms, the post-development peak discharge rates shall be in accordance with the approved release rate map for the individual watershed.

ARTICLE IV - E&S STANDARDS

§ 174-17. Erosion and Sedimentation Requirements During Regulated Earth Disturbance Activities.

- A. The applicant shall meet requirements as contained in 25 PA Code, Chapters 92 and 102 as required including, but not limited to:
 - (1) The implementation and maintenance of erosion and sediment control BMPs.
 - (2) Development of written plans.
 - (3) Submission of plans for approval.
 - (4) Obtaining Erosion and Sediment Control and NPDES permits.
 - (5) Maintaining plans and permits on site.
- B. Evidence of any necessary plan or permit approval for earth disturbance activities from PADEP or DCCD must be provided to the Township.
- C. A copy of the approved Erosion and Sediment Control Plan and any other permit, as required by PADEP or DCCD, shall be available at the project site at all times.
- D. Construction of temporary roadways (e.g., for utility construction, timber harvesting, etc.) shall comply with all applicable standards for erosion and sedimentation control and stream crossing regulations under 25 PA Code, Chapters 102 and 105. The Erosion and Sedimentation Control Plan shall be submitted to DCCD for approval and shall address the following, as applicable:
 - (1) Design of the roadway system, including haul roads, skid roads, landing areas, trails, and storage and staging areas.
 - (2) Runoff control structures (e.g., diversions, culverts, detention ponds, etc.).
 - (3) Stream crossings for both perennial and intermittent streams.
 - (4) Access to public roadways, including design of rock construction entrance for mud and debris control.
 - (5) A remediation plan for restoring the disturbed area through re-grading, topsoil placement, reseeding, and other stabilization techniques, as required.
- E. Additional erosion and sedimentation control design standards and criteria that must be applied where infiltration BMPs are proposed include the following:
 - (1) Areas proposed for infiltration BMPs shall be protected from sedimentation and compaction during the construction phase, as to maintain their maximum infiltration capacity.

- (2) Infiltration BMPs shall be protected from receiving sediment-laden runoff.
- (3) The source of protection for infiltration BMPs shall be identified (i.e., Silt fence, orange construction fence surrounding the perimeter of the BMP, etc.).

§ 174-18. Total Maximum Daily Load (TMDL) Requirements.

- A. Agricultural activities contributory to a watershed within Derry Township containing an established non-point source (agricultural) TMDL, shall be conducted in compliance with Chapter 102 (Erosion and Sediment Pollution Control), Chapter 91 - Section 91.36 (General Provisions related to Manure Management), and Act 38 (Nutrient Management).

ARTICLE V RIPARIAN BUFFERS

§ 174-19. Riparian Buffers.

- A. In order to protect and improve water quality, a Riparian Buffer Easement, when required by the Township, shall be created and recorded as part of any SWM Site Plan that encompasses a Riparian Buffer.
- B. Except as required by Chapter 102, the Riparian Buffer Easement shall be measured to be the greater of the limit of the 100-year floodplain or a minimum of 35 feet from the top of the streambank (on each side, to the greatest extent possible).
- C. Minimum Management Requirements for Riparian Buffers.
 - (1) Existing native vegetation shall be protected and maintained within the Riparian Buffer Easement.
 - (2) Whenever practicable invasive vegetation shall be actively removed and the Riparian Buffer Easement shall be planted with native trees, shrubs, and other vegetation to create a diverse native plant community appropriate to the intended ecological context of the site.
- D. The Riparian Buffer Easement shall be enforceable by the Township and shall be recorded in the Dauphin County Recorder of Deeds Office, so that it shall run with the land and shall limit the use of the property located therein. The Riparian Buffer Easement shall allow for the continued private ownership.
- E. Any permitted use within the Riparian Buffer Easement shall be conducted in a manner that will maintain the extent of the existing 100-year floodplain, improve or maintain the stream stability, and preserve and protect the ecological function of the floodplain.
- F. The geometric configuration of the floodplain area, condition of legacy sediment, and stability of the stream banks shall be evaluated prior to establishing a Riparian Buffer.
- G. The following conditions shall apply when public and/or private recreation trails are permitted within Riparian Buffers:
 - (1) Trails shall be for pedestrian or non-combustion bicycle use only.
 - (2) Trails shall be designed to have the least impact on native plant species and other sensitive environmental features.
- H. Septic drainfields and sewage disposal systems shall not be permitted within the Riparian Buffer Easement and shall comply with setback requirements established under 25 Pa. Code Chapter 73.

ARTICLE VI (RESERVED FOR FUTURE USE)

ARTICLE VII - DESIGN CRITERIA

§ 174-20. Design Criteria for Stormwater Management and Drainage Facilities.

A. General Design Guidelines:

- (1) Stormwater shall not be transferred from one watershed to another, unless:
 - (a) The watersheds are subwatersheds of a common watershed which join together within the perimeter of the property; or
 - (b) The effect of the transfer does not alter the peak rate discharge onto adjacent lands; or
 - (c) Easements from the effected landowner(s) are provided.
- (2) Consideration shall be given to the relationship of the subject property to the drainage pattern of the watershed. A concentrated discharge of stormwater to an adjacent property shall be either:
 - (a) Within an existing watercourse;
 - (b) Confined in an easement with an accompanying agreement from the effected property owner; or
 - (c) Returned to a pre-development flow-type condition.
- (3) Stormwater BMPs and recharge facilities are encouraged. They shall be located, designed, and constructed in accordance with the latest technical guidance published by PADEP. Additional guidance from other sources may be accepted at the discretion of the Township Engineer (a pre-application meeting is suggested).
- (4) All existing and natural watercourses, channels, drainage systems, and areas of surface water concentration shall be maintained in their existing condition unless an alteration is approved by the appropriate regulatory agency.
- (5) No outlet structure from a stormwater management facility or swale shall discharge directly onto a municipal or State roadway.
- (6) The invert of all stormwater management facilities and underground infiltration/storage facilities shall be located a minimum of two (2) feet above the seasonal high groundwater table or other soil-limiting zone. The invert of stormwater facilities may be lowered if adequate sub-surface drainage, which does not alter the existing water table level, is provided.
- (7) Stormwater management facilities excavated to carbonate rock must either be fitted with an impervious liner or over-excavated four (4) feet and refilled with a suitable material mix. Suitable backfill material is subject to the review and approval of the Township Engineer.

- (8) If, during construction of a stormwater management basin in an area underlain by carbonate rock, a void or sinkhole is found, a geological evaluation of the proposed location shall be conducted to determine susceptibility to further sinkhole formations. A certification note shall be provided on the as-built plans and signed and sealed by a qualified design professional. The design of all facilities over carbonate rock formations shall include measures to prevent ground water contamination and, where necessary, sinkhole formation. The Township may require the installation of an impervious liner in detention basins. The Township may require a detailed hydrogeologic investigation. The Township may require the developer or Applicant to provide safeguards against groundwater contamination for uses which may cause groundwater contamination, should there be a mishap or spill.
- (9) The type, location, and number of BMP plantings (or applicable seed mixture) shall be provided with specifications for all stormwater management facilities and shall be specific for each type of facility.
- (10) Design features must be provided to ensure the infiltration properties/rates of soils are being maintained at design rates where sediment control BMPs will be converted to Post-Construction BMPs.
- (11) The drainage system shall be designed to convey the post-development 100-year storm event to any detention basin in order to meet Rate Controls requirements.

B. Stormwater Management Facilities designed as open basin or ponds with a depth of water equal to or greater than three (3) feet measured from the lowest point inside a facility to the crest of the emergency spillway shall be subject to the following:

- (1) Any stormwater management facility designed to store runoff and requiring a berm or earthen embankment shall be designed to provide an emergency spillway to handle peak rate of stormwater runoff up to and including the 100-year post-development flow, with a blocked primary outlet structure.
- (2) The height of a berm or earthen embankment must be set to provide a minimum one (1) foot of freeboard through the spillway, above the maximum water surface elevation computed when the spillway functions for the 100-year post-development inflow, with a blocked outlet structure.
- (3) The primary outflow structure must be designed to pass all design storms (up to and including the 100-year event) without discharging through the emergency spillway.
- (4) The maximum water depth within any stormwater management facility shall be no greater than eight (8) feet when functioning through the primary outlet structure.
- (5) Emergency spillways shall be armored to prevent erosion during the 100-year post-development flow, with blocked primary outlet structure. Synthetic liners or riprap may be used, and calculations sufficient to support proposed armor must be

provided. An earthen plug must be used to accurately control the spillway invert if riprap is the proposed armoring material. Emergency spillway armor must extend up the sides of the spillway and continue at full width to a minimum of ten (10) feet past the toe of slope.

- (6) A stormwater management facility berm cross-section must be at least five (5) feet wide at the top and eight (8) feet wide through the emergency spillway. For fill embankments, the side slopes shall be no steeper than 3:1 on the inside of the facility and 2:1 on the outside of the facility. For cut slopes, the side slopes shall be no steeper than 2:1.
- (7) A cutoff and key trench of impervious material shall be provided under all embankments which are four (4) feet or greater in height.
- (8) Soils used for the construction of stormwater management facilities shall have low-erodibility factors ("K" factors) (refer to E&S Manual) and be identified on the SWM Site Plan.
- (9) Trash racks must be provided to prevent clogging of primary outflow structure stages for all orifices equivalent to twelve (12) inches or smaller in diameter. Trash racks shall be designed to be removable for cleaning and detailed on the SWM Site Plan.
- (10) Anti-seep collars must be provided on all outflow culverts in accordance with the methodology contained in the latest edition of the E&S Manual. An increase in seepage length of 15% must be used in accordance with the requirements for permanent anti-seep collars.
- (11) Conventional, non-BMP stormwater management facilities (i.e. dry detention basins) must empty over a period of time not less than twenty-four (24) hours and not more than seventy-two (72) hours from the end of the facility's inflow hydrograph. Infiltration tests performed at the facility's location and proposed basin bottom depths, in accordance with the BMP Manual, must support time-to-empty calculations if infiltration is a factor in the sizing of the stormwater management facility. (Refer also to §174-14.K)
- (12) To promote water quality and groundwater recharge for frequent storm events, impervious low-flow channels are not permitted within stormwater management facilities. Facilities designed as water quality/infiltration BMPs may have a bottom slope of zero (0%). Minimal maintenance, saturation-tolerant vegetation must be provided in basins designed as water quality/infiltration BMPs. Conventional, non-BMP stormwater management facilities must have a minimum slope of 1%, extending radially out from the primary outlet structure. Water storage below the lowest outlet structure stage (i.e., dead storage) is permitted in stormwater management facilities designed as water quality/infiltration BMPs.
- (13) Stormwater management facility bottom elevations must be greater than adjacent floodplain elevations (FEMA or HEC-RAS analysis). If no floodplain is defined,

bottom elevations must be higher than existing ground elevations fifty (50) feet from top of stream bank in the vicinity of the facility.

- (14) Basin outflow culverts discharging into floodplains must account for tailwater. Tailwater corresponding to the 100-year floodplain elevation may be used for all design storms, or the Applicant may elect to determine flood elevations of the adjacent watercourse for each design storm. The floodplain is assumed to be fifty (50) feet from top of stream bank in areas where a floodplain is not designated, or where no other evidence is provided.
- (15) Applications proposing more than four (4) feet of open stormwater storage depth shall demonstrate a means of prohibiting unauthorized access. Where fence and gates are proposed, a minimum 4-foot high fence of material acceptable to the Township with 8-foot wide self-closing, self-latching gates must be provided.
- (16) Exceptions to these requirements may be made at the discretion of the Township for BMPs that retain or detain water but are of a much smaller scale than traditional stormwater management facilities.

C. Storm Sewer Facilities:

- (1) Storm sewers must be able to convey post-development runoff from a 10-year design storm without surcharging inlets, where appropriate. When connecting to an existing storm sewer system, the Applicant must demonstrate that the proposed system will not exacerbate any existing stormwater problems, that adequate downstream capacity exists, and the existing pipes are in satisfactory condition.
- (2) A minimum pipe size of fifteen (15) inches in diameter shall be used in all public or private roadway systems. Pipes shall be designed to provide a minimum velocity of 2.5 feet per second when flowing full, but in all cases, the slope shall be no less than 0.5%. Arch pipe or elliptical pipe of an equivalent cross-sectional area may be substituted in lieu of circular pipe where cover or utility conflict conditions exist.
- (3) HDPE pipe or reinforced concrete pipe shall be used in all public or private roadway systems and in all stormwater management facilities that are dedicated to the Township. The use of corrugated metal pipe is prohibited.
- (4) In proposed curbed roadway sections, the maximum encroachment of water on the roadway pavement shall not exceed half of a through travel lane or one (1) inch less than the depth of curb during the 10-year design storm of 5-minute duration. Gutter depth shall be verified by inlet capture/capacity calculations that account for road slope and opening area. The maximum distance between inlets in curbed roadway sections shall be no more than six-hundred (600) feet, however access to underground pipes shall be provided every three-hundred (300) feet.
- (5) Standard Type "C" inlets with 8-inch hoods shall be used along vertical concrete curbs roadway networks. Type "C" inlets with 10-inch hoods that provide a 2-inch

sump condition may be used with approval of the Township Engineer when roadway longitudinal slopes are 1.0% or less.

- (6) For inlets containing a change in pipe size, the elevation for the crown of the pipes shall be the same, or the smaller pipe's crown shall be at a higher elevation.
- (7) All inlets shall provide a minimum 2-inch drop between the lowest inlet pipe invert elevation and the outlet pipe invert elevation.
- (8) On curbed sections, a double inlet shall be placed at the low point of sag vertical curves, or an inlet shall be placed at the low point and on each side of the low point at a distance not to exceed 100 feet, or at an elevation not to exceed 0.2 feet above the low point.
- (9) At all roadway low points, swales and easements shall be provided behind the curb or swale and through adjacent properties to channelize and direct any overflow of stormwater runoff away from dwellings and structures.
- (10) Inlets shall be placed so drainage cannot cross intersections or street centerlines.
- (11) All inlets in paved areas shall have heavy duty bicycle-safe grating consistent with PennDOT Publication 72M, latest edition. A note to this effect shall be added to the SWM Site Plan or inlet details therein.
- (12) Inlets must be sized to accept the specified pipe sizes without knocking out any of the inlet corners. All pipes entering or exiting inlets shall be cut flush with the inlet wall. A note to this effect shall be added to the SWM Site Plan or inlet details therein.
- (13) Inlets shall have weep holes covered with geotextile fabric placed at appropriate elevations to completely drain the subgrade prior to placing the base and surface course on roadways.
- (14) Inlets, junction boxes, or manholes greater than five (5) feet in depth shall be equipped with ladder rungs and shall be detailed on the SWM Site Plan.
- (15) Inlets shall not have a sump condition in the bottom (unless designed as a water quality BMP). Outlet pipes shall be flush with the bottom of the box or concrete channels shall be poured.
- (16) Inlets, manholes, pipes, and culverts shall be constructed in accordance with the specifications set forth in PennDOT's Publication 408, latest edition, and as detailed in the PennDOT's Publication 72M - Standards for Roadway Construction (RC), latest edition, or as approved by the Township Engineer. All material and construction details (inlets, manholes, pipe trenches, etc.), must be shown on the SWM Site Plan, and a note added that all construction must be in accordance with PennDOT's Publication 408 and PennDOT's Publication 72M, latest editions. A note shall be added to the plan stating that all frames, concrete top units, and grade adjustment rings shall be set in a bed of full mortar according to Publication

408.

- (17) Accessible drainage structures shall be located on continuous storm sewer systems at all vertical dislocations, at all locations where a transition in storm sewer pipe sizing is required, at all vertical and horizontal angle points exceeding 5 degrees, and at all points of convergence of two or more storm sewer pipes.
- (18) All storm drainage piping (equal to or greater than 12 inches) discharging to the ground surface shall be provided with either reinforced concrete headwalls and end sections, or with plastic or metal pipe end sections compatible with the pipe size involved in accordance with PennDOT Publication 408, latest edition, and Publication 72M, latest edition.
- (19) Outlet protection shall be provided at all surface discharge points with storm drainage piping (equal to or greater than 12 inches) in order to minimize erosion consistent with the E&S Manual.
- (20) Pavement base drain shall be provided at all low points in cut areas, toe of slope areas, and other areas as dictated by proven engineering principles and design judgment. All base drains shall be in accordance with PennDOT Publication 408. Field conditions may cause underdrain and pavement base drain to be installed at locations not depicted on approved drawings.
- (21) Headwalls shall be provided with a protective barrier device to discourage entry of the storm sewer pipe by unauthorized persons. Such protection devices shall be designed to be removable for cleaning.
- (22) Pipe anchors are required for pipes in excess of twenty percent (20%) slope.

D. Swale Conveyance Facilities:

- (1) Swales must be able to convey post-development runoff from a 10-year design storm with six (6) inches of freeboard to the top of the swale.
- (2) Swales shall have side slopes no steeper than 3:1.
- (3) All swales shall be designed and labeled on the SWM Site Plan. Details shall be provided to adequately construct and maintain the design dimension of the swales.
- (4) Swales shall be designed for stability using velocity or shear criteria. Velocity criteria may be used for channels with less than 10% slope. Shear criteria may be used for all swales. Documentation must be provided to support velocity and/or shear limitations used in calculations.
- (5) Where swale bends occur, the computed velocities or shear stresses shall be multiplied by the following factor for the purpose of designing swale erosion protection:
 - (a) 1.75 – When swale bend is 30 to 60 degrees

(b) 2.00 – When swale bend is 60 to 90 degrees

(c) 2.50 – When swale bend is 90 degrees or greater

(6) Swales must be designed for both temporary and permanent conditions in accordance with the latest E&S Manual.

(7) Swales shall be encompassed within a proposed stormwater easement.

E. Driveway Connections:

(1) Driveways shall not be sloped to discharge water into the travel lane of the roadway.

(2) Driveway shall be sloped or crowned to allow runoff to discharge to pervious areas to the maximum extent practicable.

(3) Driveways must be stabilized to prevent them from eroding onto public rights of way.

(4) In order to provide a safe and convenient means of access, grades of driveways shall not exceed a 7% grade within twenty (20) feet of the edge of adjacent street paving.

(5) Provide the left and right roadway grade, posted speed limit, required minimum sight distance, actual sight distance and an actual sight distance triangle for any proposed driveway.

§ 174-21. Calculation Methodology.

A. All calculations shall be consistent with the guidelines set forth in the BMP Manual.

B. Stormwater runoff from all development sites shall be calculated using either the Rational Method or a Soil Cover Complex methodology. Methods shall be selected by the Qualified Professional based on the individual limitations and suitability of each method for a particular site.

C. Rainfall Values:

(1) Rational Method – The Pennsylvania Department of Transportation Drainage Manual, Intensity-Duration-Frequency Curves, Publication 584, Chapter 7A, latest edition, shall be used in conjunction with the appropriate time of concentration and return period.

(2) Soil Cover Complex Method – The Soil Conservation Service Type II, 24-hour rainfall distribution shall be used in conjunction with rainfall depths from NOAA Atlas 14, latest values for the site location. (Refer also to §174-14.K)

D. Peak Flow Rates:

- (1) Rational Method – May be used for drainage areas up to 20 acres. Extreme caution should be used by the Qualified Professional if the watershed has more than one main drainage channel, if the watershed is divided so that hydrologic properties are significantly different in one versus the other, if the time of concentration exceeds 60 minutes, or if stormwater runoff volume is an important factor. The combination of Rational Method hydrographs based on timing shall be prohibited.
 - (a) The use of the Modified Rational Method to design stormwater management facilities must be approved by the Township Engineer.
- (2) Soil Cover Complex Method – May be used for drainage areas greater than 20 acres. This method is recommended for design of stormwater management facilities and where stormwater runoff volume must be taken into consideration.
- (3) For comparison of peak flow rates, flows shall be rounded to a tenth of a cubic foot per second (cfs).

E. Runoff Coefficients:

- (1) Rational Method – Use Table C-1 (Appendix C).
- (2) Soil Cover Complex Method – Use Table C-2 (Appendix C).
- (3) For the purposes of pre-development peak flow rate and volume determination, existing non-forested pervious area conditions shall be considered as meadow (good condition).
- (4) For the purposes of pre-development volume determination, 20% of existing impervious area, when present on the project site, and contained within the new proposed limit of disturbance, shall be considered meadow (good condition) for pre-development hydrologic calculations for re-development.

F. Design Storm:

- (1) All drainage facilities (inlets, pipes, and swales) shall be designed to safely convey the 10-year storm.
- (2) All stormwater management facilities shall be verified by routing the proposed 1-year, 2-year, 10-year, 25-year, 50-year, and 100-year hydrographs through the facility using the storage indication (Modified Puls) method. The design storm hydrograph shall be computed using a calculation method that produces a full hydrograph.

- (3) The stormwater management and drainage system shall be designed to safely convey the post-development 100-year storm event to stormwater detention facilities, for the purpose of meeting peak rate control.
- (4) All structures (culverts or bridges) proposed to convey runoff under a municipal road shall be designed to pass the 50-year design storm with a minimum 1 foot of freeboard measured below the lowest point along the top of the roadway.
- (5) All designs within State or Federal rights-of-way or that fall under the design criteria of any higher authority must meet the requirements of that agency in addition to meeting the minimum requirements of this Chapter.

G. Time of Concentration:

- (1) Time of concentration shall be computed using the NRCS Segmental Method as described in TR-55 (SCS 1986 or most current update). The length of sheet flow shall be limited to 100 feet. The Manning's "n" Roughness Coefficient for TR-55 sheet flow can be found in Table C-4 (Appendix C). Time of concentration for channel and pipe flow shall be computed using Manning's equation.
- (2) For sites with insignificant channelized flow and less than 20% impervious coverage, the time of concentration may be computed using the NRCS equation for lag time:

$$\text{Time of Concentration} = T_c = [(T_{lag}/.6) * 60] \text{ (minutes)}$$

$$T_{lag} = L^{0.8} \frac{(S+1)^{0.7}}{1900\sqrt{Y}}$$

Where:

T_{lag} = Lag time (hours)

L = Hydraulic length of watershed (feet)

Y = Average overland slope of watershed (percent)

S = Maximum retention in watershed as defined by: $S = [(1000/CN) - 10]$

CN = NRCS Curve Number for watershed as defined by the NRCS Loss Method

- (3) Additionally, the following provisions shall apply to calculations for time of concentration:
 - (a) The post-development time of concentration shall never be greater than the pre-development time of concentration for any watershed or subwatershed.
 - (b) The minimum time of concentration for any watershed shall be 5 minutes.
 - (c) The designer may choose to assume a 5-minute time of concentration for any post-development watershed or subwatershed without providing any computations.

- (d) The designer must provide computations for all pre-development time of concentration paths. A 5-minute time of concentration cannot be assumed for pre-development.
 - (e) Undetained fringe areas (areas that are not tributary to a stormwater facility but where a reasonable effort has been made to convey runoff from all new impervious coverage to best management practices) may be assumed to represent the pre-development conditions for purpose of time of concentration calculations.
- H. Drainage areas tributary to sinkholes or closed depressions in areas underlain by limestone or carbonate geologic features shall be excluded from the modeled point of analysis defining pre-development flows. If left undisturbed during construction activities, areas draining to closed depressions may also be removed from peak runoff rates in the post-development analysis. Additional contributing runoff shall not be directed to existing sinkholes or closed depressions.
 - I. Where uniform flow is anticipated, the Manning's equation shall be used for hydraulic computations and to determine the capacity of open channels, pipes, and storm sewers. The Manning's equation should not be used for analysis of pipes under pressure flow or for analysis of culverts. Manning's "n" values shall be obtained from Table C-3 (Appendix C). Inlet control shall be checked at all inlet boxes to ensure the headwater depth during the 10-year design event is contained below the top of grate for each inlet box.
 - J. The Township may approve the use of any generally accepted full hydrograph approximation technique that shall use a total runoff volume that is consistent with the volume from a method that produces a full hydrograph.
 - K. The Township has the authority to require that computed existing runoff rates be reconciled with field observations, conditions, and site history. If the designer can substantiate, through actual physical calibration, that more appropriate runoff and time of concentration values should be utilized at a particular site, then appropriate variations may be made upon review and approval by the Township.

ARTICLE VIII – STORMWATER MANAGEMENT (SWM) SITE PLAN AND REPORT REQUIREMENTS

§ 174-22. General Requirements.

- A. For any of the activities regulated by this Chapter and not eligible for the exemptions provided in §174-14, the final approval of subdivision and/or land development plans, the issuance of any zoning, building or occupancy permit, or the commencement of any land disturbance activity, may not proceed until the Applicant has received written approval of a SWM Site Plan from the Township.

§ 174-23. SWM Site Plan and Report Contents.

- A. The SWM Site Plan and SWM Site Report shall consist of all applicable calculations, maps, and plans. All SWM Site Plan materials shall be submitted to the Township in a format that is clear, concise, legible, neat, and well organized; otherwise, the SWM Site Plan shall be rejected.
- B. Appropriate sections from the Township Subdivision and Land Development Ordinance, and other applicable local ordinances, shall be followed in preparing the SWM Site Plan.
- C. SWM Site Plan shall include (but not be limited to):
 - (1) Plans no larger than 22-inch x 36-inch sheets and in a form that meets the requirements for recording in the Office of the Recorder of Deeds of Dauphin County.
 - (2) The name of the development; name and location and/or address of the property site; name, address, telephone number, and e-mail address of the Applicant/Owner of the property; and name, address, telephone number, e-mail address, and engineering seal and signature of the individual preparing the SWM Site Plan.
 - (3) The date of submission and dates of all revisions.
 - (4) A graphical and written scale on all drawings and maps.
 - (5) A north arrow on all drawings and maps.
 - (6) A location map at a minimum scale of 1 inch equals 1,000 feet.
 - (7) Metes and bounds description of the entire tract perimeter, existing and proposed easements, and rights-of-way.
 - (8) Existing and proposed contours at minimum intervals of two (2) feet.
 - (9) Existing waterbodies within the project area including streams, lakes, ponds, field-delineated wetlands or other bodies of water, sinkholes, flood hazard boundaries (FEMA-delineated floodplains and floodways), all sensitive environmental features,

areas of natural vegetation to be preserved, the total extent of the upstream area draining through the site, and overland drainage paths.

- (10) All existing and proposed utilities, on-lot wastewater facilities, water supply wells, sanitary sewers, and water lines on and within fifty (50) feet of property lines.
- (11) A key map showing all existing man-made features beyond the property boundary that may be affected by the project.
- (12) Soil names and boundaries with identification of the Hydraulic Soil Group (HSG) classification.
- (13) The proposed limit of disturbance line and associated proposed disturbed acres.
- (14) Proposed structures, roads, paved areas, buildings, and other improvements including plans and profiles of roads and paved areas and floor elevations of buildings.
- (15) Horizontal alignment, vertical profiles, and cross-sections of all open channels, pipes, swales, and other BMPs. Pipe profiles shall include the types of pipes, inlet boxes and inlet grates.
- (16) The overall stormwater management concept for the project, including the location and clear identification of the nature of permanent stormwater BMPs. This information shall include the limits of design impervious area and, where applicable, modification of design for impervious area in excess of that specified.
- (17) The location of all erosion and sedimentation control facilities.
- (18) A minimum 20-foot wide access easement around all stormwater management facilities that would provide ingress to and egress from a public right-of-way. In lieu of providing an easement to the public right-of-way, a note may be added to the plan granting the Township or their designees access to all easements via the nearest public right-of-way. All easements shall be dimensioned in plan view.
- (19) Construction details for all drainage and stormwater BMPs. Where possible, guidance for modification of the design for additional impervious area shall be provided.
- (20) Location of all roof drains discharge points.
- (21) Roofs shall show flow arrows and pitch points.
- (22) Construction details of any improvements made or proposed to be made to sinkholes.
- (23) Identification of persons responsible for short-term and long-term ownership, operation, and maintenance responsibilities.

(24) Notes and Statements to be included on the Cover Sheet of the SWM Site Plan:

- (a) A statement, signed by the landowner, acknowledging that the stormwater BMPs are fixtures that cannot be altered or removed without prior approval by the Township. See Appendix G
- (b) Statement referencing the O&M Agreement and stating that the O&M Agreement is part of the SWM Site Plan.
- (c) When applicable, a note indicating that as-built survey plans will be provided for all stormwater management facilities prior to occupancy of land or structures, or the release of financial security for said facilities.
- (d) The following signature block for the Qualified Professional preparing the SWM Site Plan:

“I, _____, hereby certify that the Stormwater Management Site Plan meets all design standards and criteria of the Township of Derry Stormwater Management Ordinance, Chapter 174.”

- (e) A justification must be included in the SWM Site Plan if BMPs other than green infrastructure methods and LID practices are proposed to achieve the volume, rate and water quality controls under this Ordinance.
- (f) Refer to Appendix F for other required standard notes.
- (g) The following land coverage table:

	Total Parcel Area			Vegetative Coverage			Impervious Coverage			Permeable Hardscape Materials		
	Square Feet	Acres	%	Square Feet	Acres	%	Square Feet	Acres	%	Square Feet	Acres	%
Existing:												
Proposed:												
Total:												

- (h) The following BMP O&M table:

BMP ID#	BMP Type	Inspection Criteria	Maintenance Criteria	Latitude Longitude
Inspection, Maintenance, & Compliance Responsible Party: Responsible Party must maintain documentation for the above listed BMPs in perpetuity.				
Name	Title	Phone Number	Email	Mailing Address

- D. SWM Site Report shall include (but not be limited to):
- (1) The name of the development; name and location and/or address of the property site; name, address, telephone number, and e-mail address of the Applicant/Owner of the property; and name, address, telephone number, e-mail address, and engineering seal and signature of the individual preparing the SWM Site Report.
 - (2) Project description narrative including expected project time schedule.
 - (3) Location map showing the project site and its location relative to release rate districts.
 - (4) Drainage area maps for all watersheds and inlets depicting the time of concentration paths.
 - (5) A detailed description of the existing site conditions. A detailed site evaluation shall be completed for projects proposed in areas of carbonate geology or Karst topography, and other environmentally sensitive areas such as brownfields.
 - (6) Complete hydrologic, hydraulic, and structural computations, calculations, assumptions, and criteria for the design of all stormwater BMPs.
 - (7) Description of, justification, and actual field results for infiltration testing with respect to the type of test and test location for the design of infiltration BMPs.
 - (8) Calculations showing the total drainage area and impervious area loading rates to each BMP.
 - (9) The effect of the project (in terms of runoff volumes, water quality, and peak flows) on surrounding properties and aquatic features and on any existing municipal stormwater collection system that may receive runoff from the project site.
 - (10) Description of the proposed changes to the land surface and vegetative cover, including the type and amount of impervious area to be added.
- E. Supplemental information to be provided prior to recording of the SWM Site Plan, as applicable:
- (1) A digital PCSM BMP inventory form in Excel-compatible format.
 - (2) Signed and executed Operation and Maintenance Agreement (Appendix A).
 - (3) Signed and executed easements, as required for all on-site and off-site work.
 - (4) An Erosion and Sedimentation Control Plan and approval letter from DCCD.
 - (5) A NPDES permit.
 - (6) Permits from PADEP and ACOE.

- (7) A geologic assessment.
- (8) A wetland delineation report.
- (9) A Highway Occupancy Permit from PennDOT when utilization of a PennDOT storm drainage system is proposed or when proposed facilities would encroach onto a PennDOT right-of-way.

§ 174-24. SWM Site Plan and Report Submission.

- A. The Applicant shall submit the SWM Site Plan and SWM Report for the Regulated Activity.
- B. Where the SWM Site Plan and SWM Report are part of a subdivision or land development plan submission to the Township, the Applicant shall follow the procedures specified in Chapter 185, Article III. In all other cases, 2 paper copies and 1 digital copy of the SWM Site Plan and Report shall be submitted to the Township for review and may be distributed as follows:
 - (1) Two copies for the Township accompanied by the requisite Township application, review fee as established from time to time by resolution of the Board of Supervisors payable to the Township of Derry, and review escrow fee as directed by the Township of Derry Community Development Office.
- C. Upon approval of the SWM Site Plan and SWM Report, 5 final paper copies and 1 digital copy shall be submitted to the Township.
- D. Additional copies shall be submitted as requested by the Township, Tri-County Regional Planning Commission, DCCD, DTMA or PADEP.

§ 174-25. SWM Site Plan and Report Review.

- A. The Township shall require receipt of a complete SWM Site Plan and Report as specified in this Chapter. The Township shall review the SWM Site Plan and Report for consistency with the purposes, requirements, and intent of this Chapter.
- B. The Township shall not approve any SWM Site Plan and Report that is deficient in meeting the requirements of this Chapter. At its sole discretion and in accordance with this Article, when a SWM Site Plan and Report is found to be deficient, the Township may disapprove the submission and require a resubmission, or in the case of minor deficiencies, the Township may accept submission of modifications.
- C. The Township shall notify the Applicant in writing within 45 calendar days of an acceptable submission whether the SWM Site Plan and Report is approved or disapproved if the SWM Site Plan and Report is not part of a subdivision or land development plan. The Township will state the reasons for any disapproval in writing. The Township also may approve the SWM Site Plan with conditions and, if so, shall provide the acceptable conditions for approval in writing.

- D. If the SWM Site Plan and Report involves a subdivision or land development plan, the timing shall follow the subdivision and land development process according to Chapter 185.
- E. For any SWM Site Plan that proposes to use any BMPs other than green infrastructure and LID practices to achieve the volume and rate controls required under this Ordinance, the Township will not approve the SWM Site Plan unless it is demonstrated to the Township that green infrastructure and LID practices are not practicable.
- F. The Township of Derry Community Development Office shall not issue a zoning permit and/or building permit for any Regulated Activity if the SWM Site Plan and Report has been found to be inconsistent with this Chapter, as determined by the Township. In addition, all required permits from PADEP must be obtained prior to issuance of a zoning permit and/or building permit.

§ 174-26. Modification of Plans.

- A. A modification to a submitted SWM Site Plan and Report for a development site that involves a change in stormwater management facilities or techniques, or that involves the relocation or re-design of stormwater management facilities, or that is necessary because soil or other conditions are not as stated on the SWM Site Plan as determined by the Township, shall require a resubmission of the modified SWM Site Plan in accordance with this Chapter.

§ 174-27. Resubmission of Disapproved SWM Site Plan and Report.

- A. A disapproved SWM Site Plan and Report may be resubmitted, with the revisions addressing the Township's concerns documented in writing, to the Township in accordance with this Chapter. The applicable Township review fee must accompany a resubmission of a disapproved SWM Site Plan and Report.

§ 174-28. Authorization to Construct and Term of Validity.

- A. From the time an application for approval of a SWM Site Plan and Report is duly filed as provided in this Chapter, and while such application is pending approval or disapproval, no change or amendment of this Chapter or other governing ordinances shall affect the decision on such application adversely to the Applicant unless otherwise required by law. The Applicant shall be entitled to a decision in accordance with the provisions of the governing ordinances or plans as they stood at the time the application was duly filed. However, if an application is properly and finally denied, any subsequent application shall be subject to the intervening change in governing regulations.
- B. The Township's approval of a SWM Site Plan and Report authorizes the Regulated Activities contained in the SWM Site Plan for a maximum term of validity of 5 years following the date of approval. The Township may specify a term of validity shorter than 5 years in the approval for any specific SWM Site Plan. Terms of validity shall commence on the date the Township signs the approval for a SWM Site Plan. The 5-year or other specified period shall be extended for the duration of any litigation, including appeals, which prevent the commencement or completion of the Regulated

Activity and for the duration of any sewer or utility moratorium or prohibition which was imposed subsequent to the filing of an application for approval of a plan. In the event of an appeal filed by any party from the approval or disapproval of a plan, the 5-year period shall be extended by the total time from the date the appeal was filed until a final order in such matter has been entered and all appeals have been concluded and any period for filing appeals or requests for consideration have expired; provided, however, no extension shall be based upon any water or sewer moratorium which was in effect as of the date of the filing of an application. If stormwater management facilities included in the approved SWM Site Plan have not been constructed, or if an as-built survey plan of these facilities has not been approved within this time, then the Township may consider the SWM Site Plan disapproved and may revoke any and all permits or approvals, unless the Applicant has requested, with good cause, an extension thereof from the Township.

§ 174-29. As-Built Survey Plans, Completion Certificate, and Final Inspection.

- A. The Applicant shall be responsible for providing as-built survey plans of all stormwater BMPs included in the approved SWM Site Plan. The as-built survey plan and an explanation of any discrepancies with the approved SWM Site Plan shall be submitted to the Township.
- B. The as-built survey plan shall include:
 - (1) A Qualified Professional's signed and sealed statement of certification of completion, verifying that all permanent stormwater BMPs have been constructed in a manner consistent with the intended function of their design.
 - (2) Identification of any variation(s) from the recorded SWM Site Plan and Report, noting and including approved Construction Modifications and Field Modifications.
 - (3) The latitude and longitude coordinates for all permanent SWM BMPs at the central location of each BMP must also be submitted.
- C. After receipt of the as-built survey plan and certification of completion, the Township shall conduct a final inspection.
- D. As-built survey plans are not required for regulated activities that have not added more than 5,000 square feet of new impervious area to a site after the effective date of this Chapter.

ARTICLE IX - EASEMENTS

§ 174-30. Easements.

- A. Easements shall be established to accommodate the existence of drainageways and waterways.
- B. Easements shall be established for all on-site stormwater management or drainage facilities, including but not limited to: detention facilities (above or below ground), infiltration facilities, all stormwater BMPs, drainage swales, and other drainage facilities (inlets, manholes, pipes, etc.).
- C. Easements are required for all areas used for off-site stormwater control.
- D. All easements shall be a minimum of 20-feet wide unless special circumstances require otherwise, as deemed necessary by the Township.
- E. Whenever possible, easements shall provide ingress to and egress from a public right-of-way. In lieu of providing an easement to the public right-of-way, a note may be added to the plan granting the Township or their designees access to all easements via the nearest public right-of-way.
- F. Where possible, easements shall be centered on or parallel to side and/or rear lot lines.
- G. The following note shall be placed on the recorded plan: "Nothing shall be placed, planted, or set within an easement or right-of-way which would adversely affect the function of the easement or right-of-way, or conflict with any conditions associated with such easement or right-of-way."
- H. A note shall be placed on the SWM Site Plan identifying the party responsible for assuring the continued functionality and required maintenance of any easement and SWM facility.

ARTICLE X - MAINTENANCE RESPONSIBILITIES

§ 174-31. Financial Guarantee.

- A. The Applicant shall provide financial security to the Township for the timely installation and proper construction of all stormwater management controls as required by the approved SWM Site Plan and this Chapter. The SWM Site Plan shall not be signed nor recorded until a financial improvements agreement is executed and financial security is provided. The resolution or letter of contingent approval shall expire and be deemed to be revoked if the financial security agreement is not executed within 90 days unless a written extension is granted by the Board of Supervisors; such extension shall not be unreasonably withheld and shall be placed in writing at the request of the developer.
- B. Without limitation as to other types of financial security which the Township may approve, which approval shall not be unreasonably withheld, Federal or Commonwealth chartered lending institution irrevocable letters of credit and restrictive or escrow accounts in such lending institutions shall be deemed acceptable financial security for the purposes of this Section.
- C. Such financial security shall be posted with a bonding company or Federal or Commonwealth chartered lending institution chosen by the party posting the financial security, provided said bonding company or lending institution is authorized to conduct such business within the Commonwealth.
- D. Such financial security shall provide for, and secure to the public, the completion of any improvements which may be required on or before the date fixed in the formal action of approval or accompanying agreement for completion of the improvements.
- E. The amount of financial security to be posted for the completion of the required improvements shall be equal to 110% of the cost of completion estimated as of 90 days following the date scheduled for completion by the developer, and shall include 15% additional costs representing the estimated costs of the improvements to cover engineering and project management costs which would be necessary to have the improvements completed by the Township. Annually, the Township may adjust the amount of the financial security by comparing the actual cost of the improvements which have been completed and the estimated cost for the completion of the remaining improvements as the expiration of the 90th day after either the original date scheduled for completion or a rescheduled date of completion. Subsequent to said adjustment, the Township may require the developer to post additional security in order to assure that the financial security equals said 110% plus 15% to cover engineering and project management costs. Any additional security shall be posted by the developer in accordance with this subsection.
- F. The amount of financial security required shall be based upon an estimate of the cost of completion of the required improvements, submitted by an Applicant or developer and prepared by a professional engineer licensed as such in the Commonwealth of Pennsylvania, and certified by such engineer to be a fair and reasonable estimate of such cost. The Township, upon the recommendation of the Township Engineer, may refuse to accept such estimate for good cause shown. If the Applicant or developer and

the Township are unable to agree upon an estimate, then the estimate shall be recalculated and recertified by a third professional engineer licensed as such in the Commonwealth of Pennsylvania, and chosen mutually by the Township and the Applicant or developer. The estimate certified by the third engineer shall be presumed fair and reasonable and shall be the final estimate. In the event that a third engineer is so chosen, fees for the services of said engineer shall be paid equally by the Township and the Applicant or developer.

- G. If the party posting the financial security requires more than one year from this date of posting of the financial security to complete the required improvements, the amount of financial security may be increased by an additional 10% for each one year period beyond the first anniversary date from posting of financial security or to an amount not exceeding 110% of the cost of completing the required improvements as re-established on or about the expiration of the preceding one year period by using the above bidding procedure.
- H. As the work of installing the required improvements proceeds, the party posting the financial security may request the Board of Supervisors to release or authorize the release, from time to time, of such portions of the financial security necessary for payment to the contractor or contractors performing the work.
- I. Any such request shall be in writing addressed to the Board of Supervisors (with a copy to the Director of the Department of Community Development), and the Board of Supervisors shall have 45 days from receipt of such request within which to allow the Township Engineer to certify, in writing, to the Board of Supervisors that such portion of the work upon the improvements has been completed in accordance with the approved plan.
- J. Upon such certification, the Board of Supervisors shall release or authorize release by the bonding company or lending institution of an amount as estimated by the Township Engineer fairly representing the value of the improvements completed.
- K. The Board of Supervisors may, prior to final release at the time of completion and certification by its Engineer, require retention of 10% of the estimated cost of the aforesaid improvements.
- L. Where the Board of Supervisors accepts dedication of all or some of the required improvements following completion, the Board of Supervisors may require the posting of financial security to secure structural integrity of said improvements as well as the functioning of said improvements in accordance with the design and specifications as depicted on the final plan for a term not to exceed 18 months from the date of acceptance of dedication.
- M. Said financial security shall be of the same type as otherwise required in this Section with regard to installation of such improvements, and the amount of the financial security shall not exceed 15% of the actual cost of installation of said improvements.
- N. If financial security has been provided in lieu of the completion of improvements required as a condition for the final approval of a plan as set forth in this Section, the Township of Derry shall not condition the issuance of building, grading, or other permits relating to

the erection or placement of improvements, including buildings, upon the lots or land as depicted upon the plan upon actual completion of the improvements depicted upon the approved final plan.

- O. Moreover, if said financial security has been provided, occupancy permits for any building or buildings to be erected shall not be withheld following the improvement of the streets providing access to and from existing public roads to such building or buildings to a mud-free or otherwise permanently passable condition, as well as the completion of all other improvements as depicted upon the approved plan, either upon the lot or lots or beyond the lot or lots in question if such improvements are necessary for the reasonable use of, or occupancy of, the building or buildings.
- P. At the completion of the project and as a prerequisite for the release of the financial security, the Applicant shall:
 - (1) Provide a certification of completion from an engineer, architect, surveyor, or other Qualified Professional, verifying that all permanent facilities have been constructed according to the SWM Site Plan and Report and approved revisions thereto.
 - (2) Provide a set of as-built survey plans, where applicable.
 - (3) Request a final inspection by the Township to verify compliance with this Chapter, after receipt of the certification of completion and as-built survey plans by the Township.

§ 174-32. Maintenance Responsibilities.

- A. The SWM Site Plan and Report for the project site shall describe the future operation and maintenance responsibilities. The operation and maintenance description shall outline required routine maintenance actions and schedules necessary to ensure proper operation of the stormwater control facilities.
- B. The SWM Site Plan and Report for the project site shall establish responsibilities for the continuing operation and maintenance of all proposed stormwater control facilities, consistent with the following principles:
 - (1) If a development consists of structures or lots that are to be privately owned and in which streets, storm sewers, and other public improvements are to be dedicated to the Township, that portion of the stormwater control facilities/BMPs associated with the public improvements may also be dedicated to and maintained by the Township if specifically agreed to and accepted by the Township. Nothing herein is intended to require the Township to accept dedication of any improvements, facilities and/or property.
 - (2) If a development site is to be maintained in a single ownership or if storm sewers and other public improvements are to be privately owned and maintained, then the ownership and maintenance of stormwater control facilities/BMPs shall be the responsibility of the owner or private management entity.

- (3) Facilities, areas, or structures used as stormwater BMPs shall be enumerated as permanent real estate appurtenances and recorded as deed restrictions or easements that run with the land.
 - (4) A notice of the SWM Site Plan and O&M Agreement shall be recorded as a restrictive deed covenant that runs with the land.
- C. The Township, upon recommendation of the Township Engineer, shall make the final determination on the continuing maintenance responsibilities prior to final approval of the SWM Site Plan and Report. The Township may require a dedication of such facilities as part of the requirements for approval of the SWM Site Plan. Such a requirement is not an indication that the Township will accept the facilities. The Township reserves the right to accept or reject the ownership and operating responsibility for any portion of the stormwater BMPs.
 - D. If the Township accepts ownership of stormwater BMPs, the Applicant shall be required to pay a fee to offset the future cost of inspections, operations, and maintenance, and the amount of such fee shall be determined by the Township.
 - E. It shall be unlawful to alter or remove any permanent stormwater BMP required by an approved SWM Site Plan, or to allow the property to remain in a condition, which does not conform to an approved SWM Site Plan unless the Township grants an exception in writing.

§ 174-33. Maintenance Agreement for Privately-Owned Stormwater Facilities.

- A. Prior to final approval of the SWM Site Plan and Report, the person or entity responsible for the Operation and Maintenance of the BMPs shall sign an O&M Agreement in a manner and form acceptable to the Township and similar to that provided for in Appendix A, covering all stormwater BMPs that are to be privately owned. The O&M Agreement shall be recorded with the SWM Site Plan and made a part thereof.
 - (1) The owner, successor and assigns shall maintain all facilities in accordance with the approved maintenance schedule in the O&M Agreement.
 - (2) The owner shall convey to the Township easements to assure access for periodic inspections and maintenance, as necessary.
 - (3) The owner shall keep on file with the Township the name, address, and telephone number of the person or company responsible for maintenance activities; in the event of a change, new information shall be submitted by the owner to the Township within ten (10) working days of the change.
 - (4) The owner shall post any requisite financial security and pay any requisite inspection and maintenance fee.
- B. Other items may be included in the O&M Agreement where determined necessary to guarantee the satisfactory operation and maintenance of all BMP facilities. The O&M Agreement shall be subject to the review and approval of the Township and the Township Solicitor.

- C. If the person or entity responsible for the operation and maintenance of the BMPs fails to adhere to the O&M Agreement, the Township and/or DTMA or their respective designees may perform the services required and charge the owner appropriate fees. Non-payment of fees shall result in a lien against the property.

ARTICLE XI - INSPECTIONS

§ 174-34. Schedule of Inspections.

- A. PADEP or its designees normally ensure compliance with any permits issued, including those for stormwater management. In addition to PADEP compliance programs, the Township or their designee may inspect all phases of the installation of temporary or permanent stormwater management facilities.
- B. The landowner or the owner's designee (including the Township for dedicated and owned facilities) shall inspect SWM BMPs, facilities and/or structures installed under this Ordinance according to the following frequencies, at a minimum, to ensure the BMPs, facilities and/or structures continue to function as intended:
 - (1) Annually for the first 5 years.
 - (2) Once every 3 years thereafter.
 - (3) During or immediately after the cessation of a 10-year or greater storm.
- C. Inspections should be conducted during or immediately following precipitation events. A written inspection report shall be created to document each inspection. The inspection report shall contain the date and time of the inspection, the individual(s) who completed the inspection, the location of the BMP, facility or structure inspected, observations on performance, and recommendations for improving performance, if applicable. Inspection reports shall be submitted to the Township within 30 days following completion of the inspection.
- D. Stormwater BMPs may be inspected by the Township, or the Township's designee according to the inspection schedule described on the SWM Site Plan for each BMP.
 - (1) The Township will endeavor to notify the BMP owner 3 days prior to the inspection to arrange a time for the inspection.
 - (2) The Township may require copies of inspection reports of other parties and supporting documentation that the methods and materials used in the development of the BMPs are in accordance with this Chapter, in a form as stipulated by the Township.
 - (3) The Township shall conduct such inspections and charge the owner an appropriate fee in an amount as established from time to time by resolution of the Board of Supervisors, payable to Derry Township. Non-payment of fees may result in a lien against the property.
 - (4) Owner shall be responsible for all inspection fees incurred by the Township.
- E. During any stage of Earth Disturbance Activities, if the Township determines that the temporary or permanent stormwater management facilities are not being installed in accordance with the approved SWM Site Plan, the Township shall revoke any existing

permits or approvals until a revised SWM Site Plan is submitted and approved as specified in this Chapter.

§ 174-35. Right-of-Entry.

- A. Upon presentation of proper credentials, duly authorized representatives of the Township may enter at reasonable times upon any property within the Township to inspect the implementation, condition, or operation and maintenance of the stormwater BMPs in regard to any aspect governed by this Chapter.
- B. Stormwater BMP owners and operators shall allow persons working on behalf of the Township ready access to all parts of the premises for the purposes of determining compliance with this Chapter.
- C. The Township, DTMA, or their designee shall have the right to place in or on any stormwater BMP in the Township such devices as are necessary to conduct monitoring and/or sampling of the discharges from such stormwater BMP.
- D. Unreasonable delay in allowing the Township access to a stormwater BMP is a violation of this Chapter.

ARTICLE XII - ENFORCEMENT AND PENALTIES

§ 174-36. Notification.

- A. In the event that a person or entity fails to comply with the requirements of this Chapter, an approved SWM Site Plan, or fails to conform to the requirements of any permit or approval issued hereunder, the Township shall provide written notification, via certified mail, of the violation to the landowner indicated on the O&M Agreement or their successor. Such notification shall set forth the nature of the violation(s) and establish a time limit for correction of these violation(s).
- B. Failure to comply within the time specified shall subject such persons or entities to the penalties provisions of this Chapter. All such penalties shall be deemed cumulative and shall not prevent the Township from pursuing any and all other remedies. It shall be the responsibility of the owner of the real property on which any Regulated Activity is proposed to occur, is occurring, or has occurred, to comply with the terms and conditions of this Chapter.

§ 174-37. Enforcement.

- A. The Township is hereby authorized and directed to enforce all of the provisions of this Chapter. The approved SWM Site Plan shall be on file at the project site throughout the duration of the construction activity. The Township or their designee may make periodic inspections during construction.
- B. Adherence to approved SWM Site Plan:
 - (1) It shall be unlawful for any person, firm, or corporation to undertake any Regulated Activity on any property except as provided for by an approved SWM Site Plan and pursuant to the requirements of this Chapter.
 - (2) It shall be unlawful to alter or remove any control structure required by the SWM Site Plan pursuant to this Chapter.
 - (3) It shall be unlawful to allow a property to remain in a condition that does not conform to an approved SWM Site Plan.
- C. The Township and/or DTMA may take enforcement actions against an owner for any failure to satisfy the provisions of this Chapter.

§ 174-38. Public Nuisance.

- A. A violation of any provision of this Chapter is hereby deemed a public nuisance.
- B. Each day that a violation continues shall constitute a separate violation.

§ 174-39. Suspension and Revocation.

- A. Any approval or permit issued by the Township may be suspended or revoked for any or all of the following reasons:
 - (1) Non-compliance with or failure to implement any provision of the approved SWM Site Plan or O&M Agreement.
 - (2) A violation of any provision of this Chapter or any other applicable law, ordinance, rule, or regulation relating to the Regulated Activity.
 - (3) The creation of any condition or the commission of any act during the Regulated Activity which constitutes or creates a hazard or nuisance, pollution, or which endangers the life or property of others.
- B. A suspended approval or permit may be reinstated by the Township when:
 - (1) The Township or their designee has inspected and approved the corrections to the violation(s) that caused the suspension.
 - (2) The Township is satisfied that the violation(s) has been corrected.
- C. An approval that has been revoked by the Township cannot be reinstated. The Applicant may apply for a new approval under the provisions of this Chapter.

§ 174-40. Penalties.

- A. Anyone violating the provisions of this Chapter shall be guilty of a summary offense and upon conviction shall be subject to a fine of not more than \$1,000.00 for each violation, recoverable with costs. Each day that the violation continues shall be a separate offense and penalties shall be cumulative.
- B. In addition, the Township, through its solicitor, may institute injunctive, mandamus, or any other appropriate action or proceeding at law or in equity for the enforcement of this Chapter. Any court of competent jurisdiction shall have the right to issue restraining orders, temporary or permanent injunctions, mandamus, or other appropriate forms of remedy or relief.

§ 174-41. Appeals.

- A. Any person aggrieved by any action of the Township or its designee, relevant to the provisions of this Chapter, may appeal to the Township within 30 days of that action.
- B. Any person aggrieved by any decision of the Township, relevant to the provisions of this Chapter, may appeal to the Dauphin County Court of Common Pleas within 30 days of the Township's decision.

ARTICLE XIII - PROHIBITIONS

§ 174-42. Prohibited Discharges and Connections.

- A. Any drain (including indoor drains and sinks) or conveyance, whether on the surface or underground, that allows any non-stormwater discharge including sewage, process wastewater, and wash water to enter the Township's separate storm sewer system or Waters of the Commonwealth is prohibited.
- B. Any drain or conveyance connected from a commercial or industrial land use to the Township's separate storm sewer system which has not been documented in plans, maps, or equivalent records and approved by the Township is prohibited.
- C. No person shall allow, or cause to allow, discharges into the Township's separate storm sewer system or into surface Waters of the Commonwealth which are not composed entirely of stormwater, except: (1) as provided in §174-42.D below, and (2) discharges allowed under a State or Federal permit.
- D. The following discharges are authorized unless they are determined to be significant contributors to pollution to the Waters of the Commonwealth:
 - (1) Discharges or flows from firefighting activities.
 - (2) Discharges from potable water sources including water line flushing and fire hydrant flushing, if such discharges do not contain detectable concentrations of Total Residual Chlorine (TRC).
 - (3) Non-contaminated irrigation water, water from lawn maintenance, landscape drainage and flows from riparian habitats and wetlands.
 - (4) Diverted stream flows and diverted springs.
 - (5) Non-contaminated pumped ground water and water from foundation and footing drains and crawl space pumps.
 - (6) Non-contaminated HVAC condensation and water from geothermal systems.
 - (7) Residential (i.e., not commercial) vehicle wash water where cleaning agents are not utilized.
 - (8) Non-contaminated hydrostatic test water discharges, if such discharges do not contain detectable concentrations of TRC.
 - (9) Pavement wash waters where spills or leaks of toxic or hazardous materials have not occurred (unless all spill material has been removed) and where detergents are not used.
 - (10) Routine external building washdown (which does not use detergents or other compounds).
 - (11) Dechlorinated swimming pool discharges.

- E. In the event that the Township or PADEP determines that any of the discharges identified in §174-42.D significantly contribute to pollution of Waters of the Commonwealth, or if the Township is so notified by PADEP, the Township will notify the responsible person(s) to cease the discharge.
- F. Upon notice provided by the Township or PADEP under §174-42.E, the discharger will have a reasonable time, as determined by the Township or PADEP, to cease the discharge, consistent with the degree of pollution caused by the discharge.
- G. Nothing in this Section shall affect a discharger's responsibilities under Commonwealth Law.

§ 174-43. Roof Drains and Sump Pumps.

- A. Roof drains and/or sump pumps shall discharge to infiltration areas, vegetative BMPs, or pervious areas unless it is demonstrated by the owner/applicant that it is technically infeasible.
- B. Roof drains and/or sump pumps shall not be connected to storm sewers or roadside ditches, except where advantageous to the Township.
- C. Roof drains and/or sump pumps shall not be connected to streets, unless it is demonstrated by the owner/applicant that it is absolutely necessary, and that this will not cause ice, standing water, or overloading of existing stormwater facilities.
- D. Roof drains and/or sump pumps shall not be connected to public sanitary sewers under any circumstance, unless permitted in writing by DTMA.

§ 174-42. Alteration of BMPs.

- A. No person shall modify, remove, fill, landscape, or alter any existing stormwater BMP, facilities, areas, or structures unless it is part of an approved maintenance program, without the written approval of the Township.
- B. No person shall place any structure, fill, landscaping, or vegetation into a stormwater BMP, facilities, areas, structures, or within a drainage easement which would limit or alter the functioning of the BMP, without the written approval of the Township.

ARTICLE XIV - FEES AND EXPENSES

§ 174-44. General.

- A. The Township review fee required by this Chapter shall be as established from time to time by resolution of the Township Board of Supervisors to defray review and other costs incurred by the Township in the administration of this Chapter. The Applicant shall pay all fees.

- B. The Applicant shall also reimburse the Township for costs that the Township has incurred by the Township Engineer, Township Solicitor, and/or other professional consultant(s) that the Township, in its sole discretion, deems necessary in order to adequately and properly administer the requirements of this Chapter and report the findings to the Township. The Township shall advise the Applicant of the reimbursement amount required within 30 days of being billed by the Township Engineer and/or professional consultant(s). The Applicant shall reimburse the Township within 30 days of receipt of the Township's notice of payment due.
 - (1) In the event the Applicant disputes the amount of any such review fee, the Applicant shall, within 14 days of the receipt of the notice of payment due, notify the Township that such fees are disputed, in which case the Township shall not delay or disapprove a plan submission due to the Applicant's fee dispute. The Township may condition the approval of plan submissions upon the Township having received full payment as stated in the notice of payment due.
 - (2) If, within 20 days of the notice of payment due, the Applicant and Township cannot agree on the amount of expenses incurred by the Township, the Applicant and the Township shall jointly, by mutual agreement, appoint another professional engineer of the same profession or discipline as the Township Engineer or professional consultant whose fees are being disputed to make a determination as to the amount thereof which is reasonable and necessary.
 - (3) The professional engineer appointed, either by mutual agreement of the Township and Applicant or by the President Judge of the Court of Common Pleas, shall hear such evidence and review such documentation as the professional engineer in his or her sole opinion deems necessary and render a decision within 50 days of the billing date. Such decision shall be final and binding upon both the Township and the Applicant. The Applicant shall be required to pay the entire amount determined in the decision within 30 days of such decision.
 - (4) The Applicant shall pay the fee of the appointed professional engineer for determining the reasonable and necessary expense, if the amount of payment required in the decision is equal to or greater than the original bill. If the amount of payment required in the decision is less than the original bill by \$1,000 or more, the Township shall pay the fee of the professional engineer, but otherwise the Township and the Applicant shall each pay 1/2 of the fee of the appointed professional engineer.

§ 174-45. Expenses Covered by Fees.

- A. The fees required by this Chapter shall, at a minimum, cover:
- (1) Administrative and clerical costs.
 - (2) Review of the SWM Site Plan and Report by the Township.
 - (3) Pre-construction meetings.
 - (4) Inspection of stormwater management facilities/BMPs and drainage improvements during construction.
 - (5) Final inspection upon completion of the stormwater management facilities/BMPs and drainage improvements presented in the SWM Site Plan.
 - (6) Any additional work required to enforce any permit provisions regulated by this Chapter, correct violations, and assure proper completion of stipulated remedial actions.

§ 174-46. Recording of Approved SWM Site Plan and Related Agreements.

- A. The owner or agent of any land upon which permanent BMPs will be placed, constructed, or implemented, as described in the SWM Site Plan, shall record the following documents in the Office of the Recorder of Deeds of Dauphin County, within 90 days of approval of the SWM Site Plan by the Township:
- (1) The SWM Site Plan.
 - (2) O&M Agreement in a manner and form acceptable to the Township and similar to that provided for in Appendix A.
 - (3) Deed restrictions, easements, and/or covenants as required under §174-30 and under §174-32.B(3) and (4).
- B. The Township may suspend or revoke any approvals granted for the project site upon discovery of the failure of the owner to comply with this Chapter.

SECTION II. SEVERABILITY.

It is hereby declared to be the legislative intent that if a court of competent jurisdiction declares any provisions of this Ordinance to be invalid or ineffective in whole or in part, the effect of such decision shall be limited to those provisions which are expressly stated in the decision to be invalid or ineffective, and all other provisions of this Ordinance shall continue to be separately and fully effective. The Board of Supervisors hereby declares that it would have passed this Ordinance and each section or part thereof, other than any part declared invalid, if it had advance knowledge that any part would be declared invalid.

SECTION III. REPEALER.

All ordinances or parts of ordinances which are inconsistent herewith are hereby repealed.

SECTION IV. EFFECTIVE DATE.

This Ordinance shall become effective five (5) days after enactment.

DULY ENACTED AND ORDAINED into law this 28th day of November 2023, by the Board of Supervisors of Derry Township, Dauphin County, Pennsylvania, in lawful session duly assembled.

Board of Supervisors of Derry Township

By: 
E. Christopher Abruzzo - Chairman

ATTEST:  [TOWNSHIP SEAL]
Christopher S. Christman, Township Manager



APPENDIX A

(This Sample Agreement is a general sample. The actual agreement may vary in form for each application, subject to the Township's review and approval.)

SAMPLE STORMWATER OPERATION AND MAINTENANCE AGREEMENT AND ACCESS EASEMENT

Return To: *NAME OF DEVELOPER*
Developer's street address
City, State, Zip Code

Dauphin County Tax Parcel No.: 24-XXX-XXX

STORMWATER OPERATION AND MAINTENANCE AGREEMENT AND ACCESS EASEMENT

THIS AGREEMENT AND ACCESS EASEMENT, dated as of this _____ day of _____, 20____, is by and between *NAME OF DEVELOPER, street address, city state, zip code*, (hereinafter referred to as "**Grantor**"), and **DERRY TOWNSHIP**, a township of the second class, with offices located at 600 Clearwater Road, Hershey, Pennsylvania, 17033 (hereinafter referred to as "**Grantee**" and/or "**Township**").

WHEREAS, Grantor is the lawful owner of a parcel of ground located at _____ in Derry Township and more particularly identified as Dauphin County Tax Parcel No. 24-____-____ (hereinafter referred to as "**Property**"); and

WHEREAS, Grantor has presented a proposed stormwater management plan to Township, which plan is attached hereto and marked as **Exhibit "A"** and made a part hereof, consisting of ____ sheets, dated _____, 20____, last revised _____, prepared by _____ for Stormwater Management Plan Application No. S-20____-____ on the above-referenced Property (hereinafter referred to as the "**Plan**"); and

WHEREAS, the Township Engineer issued a review letter dated _____, 20____, providing for certain requirements Grantor needed to comply with in order to proceed with the Plan, with one such requirement being the execution of the requisite Stormwater Management Operation and Maintenance Agreement; and

WHEREAS, in order for Grantor to proceed with the Plan, Grantor must construct certain stormwater management facilities as shown on the Plan and in accordance with the above-referenced _____, 20____ correspondence from HRG, Inc. (hereinafter referred to as "**Stormwater Management Facilities**"), consisting of the installation of stormwater BMPs and related facilities, as shown on the Plan and described in the Cost Estimate attached hereto and marked as **Exhibit "B"**; and

WHEREAS, the parties desire that this Agreement be binding upon their grantees, heirs, successors and assigns of the Property; and

WHEREAS, the parties desire that this Agreement set forth Grantor's obligations with respect to stormwater management on the Property.

NOW, THEREFORE, the parties do hereby agree as follows:

1. Said Grantor, for and in consideration of the sum of One Dollar (\$1.00), paid, does hereby grant, convey, bargain, sell, release, and confirm unto the said Grantee, its successors and assigns, an access and inspection easement, to and over the subject Property and Stormwater Management Facilities.
2. Grantor shall post with the Grantee an escrow in the amount of _____ Dollars and Zero Cents (\$_____.00) to serve as financial security for the proper installation of the requisite Stormwater Management Facilities as described in Exhibit "B".
3. For purposes of this Agreement, Grantee shall have the full, free, unlimited and unrestricted right, liberty, privilege, and easement in common with Grantor, their successors and assigns, to enter upon the Property and inspect the Stormwater Management Facilities from time to time to insure its continued maintenance and operation by Grantor, their successors and assigns.
4. No barriers, fences, signs, plantings, or other obstruction to the free and unhampered use of the easement shall hereafter be permitted, nor shall any motor vehicles, personal property, buildings, or other structures be permitted or constructed within a portion of said Stormwater Management Facilities easement without the express written approval of Grantee.
5. The Stormwater Management Facilities shall be constructed by the Grantor, their successors and assigns, in accordance with the terms, conditions, and specifications identified on the Plan. Grantor, their successors and assigns, shall perform maintenance in accordance with the maintenance schedule for the approved Stormwater Management Facilities, including sediment removal and other maintenance requirements as deemed necessary by the Township.
6. The Grantor, their successors and assigns, shall maintain the Stormwater Management Facilities in good working order and in a manner and form acceptable to the Township so that such facilities are performing as designed.
7. The owner shall keep on file with the Township the name, address, and telephone number of the person or company responsible for maintenance activities; in the event of a change, new information shall be submitted by the owner to the Township within ten (10) working days of the change.
8. All reasonable costs for inspections of the Stormwater Management Facilities by the Grantee shall be borne by the Grantor and payable to the Grantee.
9. Grantor shall complete the Stormwater Management Facilities in a manner and form acceptable to the Township, including providing Township with an As-Built Plan when required by the Derry Township Stormwater Management Ordinance. In the event Grantor fails to timely construct and complete the Stormwater

Management Facilities in a manner and form acceptable to the Township or to provide an As-Built Plan when required, Grantor specifically agrees that the Township may and will draw any financial security referenced in and/or posted with the Township under this Agreement, or other security posted with the Township, in order to secure the Stormwater Management Facilities are constructed in a manner and form acceptable to the Township.

10. All stormwater BMPs shall be inspected annually and after any storm larger than the design storm referenced in the Report to ensure the Stormwater Management Facilities are working properly and are being maintained and repaired in a manner and form acceptable to the Township and in accordance with the BMP design in the approved Plan, and such inspections shall also consist of checking on the following items:
 - a. Trash and debris at the inlet and outlet devices. All materials shall be removed if found;
 - b. Excessive erosion or sedimentation;
 - c. Formation of sinkholes;
 - d. Cracking or settling;
 - e. Animal burrowing;
 - f. Permanently ponding areas in the bottom of a bio-retention facility;
 - g. Poorly draining infiltration devices;
 - h. Algae growth, stagnant pools, or noxious odors;
 - i. Poor distressed stands of grass;
 - j. Distressed aquatic vegetation;
 - k. Deterioration of pipe and conduits;
 - l. Deterioration of emergency spillways;
 - m. Washouts, bulges, or slumps;
 - n. Seepage at the toe of wet ponds or constructed treatment wetlands;
 - o. Unstable side slopes and embankments;
 - p. Deterioration of downstream channels;
 - q. Signs of vandalism;
 - r. Piping of water along outlet barrel;
 - s. Deterioration/scouring of energy dissipaters;

- t. Outlet protection; and
 - u. Sediment in rip-rap channels.
11. In addition to the foregoing, Grantor shall perform routine maintenance for any mechanical components as directed by the manufacturer and to routinely eliminate insects, waterlogged conditions, excess algae growth, and erosion.
 12. In the event that the Grantee determines at any time that the Stormwater Management Facilities on the Property are not functioning properly in accordance with the above-described Plan, Grantee shall provide written notice to Grantor of the defect. Within fifteen (15) calendar days of this notice, Grantor shall begin any and all repair and maintenance work necessary to restore the Stormwater Management Facilities and to correct the defect in order to insure the proper functioning of the Facilities in accordance with the approved Plan. If Grantor either refuses or neglects to perform or complete the required repair or maintenance work on the facilities, Grantee shall have the right and privilege, but not the obligation, to enter upon the Property and to perform the necessary work within its sole discretion and to lien the Property for all costs related to the required work if Grantor refuses payment.
 13. Grantor and Grantee acknowledge and agree that Grantee has no obligation to construct, repair, and/or maintain the subject Stormwater Management Facilities, and Grantor further covenants and agrees to indemnify and hold Grantee harmless from and against any and all claims, actions, causes of action, judgments, costs, expenses, and liabilities of any kind whatsoever incurred in connection with, arising from, or as a result of death, accident, injury, loss, or damage to any person or any property in or about the subject Stormwater Management Facilities arising out of the performance by Grantor, their successors and assigns, in constructing, repairing and/or maintaining the Facilities.
 14. This Agreement and easement are for the benefit of Grantee, its successors and assigns, and is appurtenant thereto and shall run with the Property.
 15. In the event that Grantee is required to enforce its rights under this easement in order to either remove an obstruction from the easement area, Grantor shall reimburse Grantee all costs and expenses, including reasonable attorneys' fees, as a result of Grantee's enforcement action.
 16. The Grantor, their successors and assigns, shall indemnify the Township and its agents and employees against any and all damage, accidents, casualties, occurrences, or claims that might arise or be asserted against the Township for the construction, presence, existence, or maintenance of the Stormwater Management Facilities by the Grantor and their successors and assigns.
 17. In the event a claim is asserted against the Township, its agents, or employees with respect to the Plan, the Township shall promptly notify the Grantor and/or their successors and assigns, and Grantor and/or their successors and assigns shall defend, at their own expense, any suit based on such claim. If any judgment or claims against the Township, its agents or employees shall be allowed, the Grantor

and their successors and assigns shall pay all costs and expenses in connection therewith. The foregoing notwithstanding, Grantor, their successors and assigns, shall not be obligated to indemnify, defend, or hold Township, its agents, or employees harmless from any actions or damages that are attributable to or result from the gross negligence or willful misconduct of the Township or its agents or employees.

18. Pursuant to, and subject to the provisions of the Pennsylvania Municipalities Planning Code, Grantor agrees to pay all reasonable bills and invoices for engineering, inspection, legal, and other professional services that Township incurs for such services for the time that the Engineer, Inspector, or other professional for Township is actually engaged as a result of the following: (1) review and approval of the Plan; (2) preparation of agreements, documents, deeds, easements, etc., incidental to the approved Plan; (3) monitoring, testing, and inspecting of the work required of Grantor under the approved Plan; (4) preparation for and attendance at meetings relating to the Plan; and (5) enforcement of the terms of this Agreement.
19. This Agreement shall be recorded in the Office of the Dauphin County Recorder of Deeds at the expense of Grantor and shall run with the land and be binding on Grantor and Grantor's heirs, successors, and assigns.

THIS AGREEMENT shall be recorded among the land records of Dauphin County, Pennsylvania and shall constitute a covenant running with the Property and/or equitable servitude, and shall be binding on the Grantor, their administrators, executors, assigns, heirs, and any other successors in interest, in perpetuity.

[SIGNATURES ON NEXT PAGE]

IN WITNESS WHEREOF, the Grantor and Grantee, intending to be legally bound hereby, have hereunto set their hands and seals the day and year first above written.

_____ **(GRANTOR)**

Print name:

DERRY TOWNSHIP (GRANTEE)

By: _____, Manager

ACKNOWLEDGEMENT

COMMONWEALTH OF PENNSYLVANIA :
: **SS.**
COUNTY OF _____ :

On the _____ day of _____, 20_____, before me a Notary Public, the undersigned officer, personally appeared _____ of _____, known to me (or satisfactorily proven) to be the person whose name is subscribed to the within instrument, and acknowledged that he/she executed the same for the purposes therein contained.

IN WITNESS WHEREOF, I have hereunto set my official hand and seal.

Notary Public

My Commission Expires:

ACKNOWLEDGMENT

COMMONWEALTH OF PENNSYLVANIA :
: **SS.**
COUNTY OF DAUPHIN :

On the _____ day of _____, 20_____, before me a Notary Public, the undersigned officer, personally appeared _____, **Manager of Derry Township**, known to me (or satisfactorily proven) to be the person whose name is subscribed to the within instrument, and acknowledged that he executed the same for the purposes therein contained.

IN WITNESS WHEREOF, I have hereunto set my official hand and seal.

Notary Public

My Commission Expires:

APPENDIX B

RESERVED

APPENDIX C, TABLE C-1 STORMWATER MANAGEMENT DESIGN CRITERIA

RATIONAL METHOD RUNOFF COEFFICIENTS

Hydrologic Soil Group and Slope Range

Land Use	A			B			C			D		
	0 to 2%	2 to 6%	6+%	0 to 2%	2 to 6%	6+%	0 to 2%	2 to 6%	6+%	0 to 2%	2 to 6%	6+%
Cultivated Land	0.08 ^a	0.13	0.16	0.11	0.15	0.21	0.14	0.19	0.26	0.18	0.23	0.31
	0.14 ^b	0.18	0.22	0.16	0.21	0.28	0.20	0.25	0.34	0.24	0.29	0.41
Pasture	0.12	0.20	0.30	0.18	0.28	0.37	0.24	0.34	0.44	0.30	0.40	0.50
	0.15	0.25	0.37	0.23	0.34	0.45	0.30	0.42	0.52	0.37	0.50	0.62
Meadow	0.10	0.16	0.25	0.14	0.22	0.30	0.20	0.28	0.36	0.24	0.30	0.40
	0.14	0.22	0.30	0.20	0.28	0.37	0.26	0.35	0.44	0.30	0.40	0.50
Forest	0.05	0.08	0.11	0.08	0.11	0.14	0.10	0.13	0.16	0.12	0.16	0.20
	0.08	0.11	0.14	0.10	0.14	0.18	0.12	0.16	0.20	0.15	0.20	0.25
Residential 1/8 acre	0.25	0.28	0.31	0.27	0.30	0.35	0.30	0.33	0.38	0.33	0.36	0.42
	0.33	0.37	0.40	0.35	0.39	0.44	0.38	0.42	0.49	0.41	0.45	0.54
Residential 1/4 acre	0.22	0.26	0.29	0.24	0.29	0.33	0.27	0.31	0.36	0.30	0.34	0.40
	0.30	0.34	0.37	0.33	0.37	0.42	0.36	0.40	0.47	0.38	0.42	0.52
Residential 1/3 acre	0.19	0.23	0.26	0.22	0.26	0.30	0.25	0.29	0.34	0.28	0.32	0.39
	0.28	0.32	0.35	0.30	0.35	0.39	0.33	0.38	0.45	0.36	0.40	0.50
Residential 1/2 acre	0.16	0.20	0.24	0.19	0.23	0.28	0.22	0.27	0.32	0.26	0.30	0.37
	0.25	0.29	0.32	0.28	0.32	0.36	0.31	0.35	0.42	0.34	0.38	0.48
Residential 1 acre	0.14	0.19	0.22	0.17	0.21	0.26	0.20	0.25	0.31	0.24	0.29	0.35
	0.22	0.26	0.29	0.24	0.28	0.34	0.28	0.32	0.40	0.31	0.35	0.46
Industrial	0.67	0.68	0.68	0.68	0.68	0.69	0.68	0.69	0.69	0.69	0.69	0.70
	0.85	0.85	0.86	0.85	0.86	0.86	0.86	0.86	0.87	0.86	0.86	0.88
Commercial	0.71	0.71	0.72	0.71	0.72	0.72	0.72	0.72	0.72	0.72	0.72	0.72
	0.88	0.88	0.89	0.89	0.89	0.89	0.89	0.89	0.90	0.89	0.89	0.90
Streets	0.70	0.71	0.72	0.71	0.72	0.74	0.72	0.73	0.76	0.73	0.75	0.78
	0.76	0.77	0.79	0.80	0.82	0.84	0.84	0.85	0.89	0.89	0.91	0.95
Open Space	0.05	0.10	0.14	0.08	0.13	0.19	0.12	0.17	0.24	0.16	0.21	0.28
	0.11	0.16	0.20	0.14	0.19	0.26	0.18	0.23	0.32	0.22	0.27	0.39
Parking	0.85	0.86	0.87	0.85	0.86	0.87	0.85	0.86	0.87	0.85	0.86	0.87
	0.95	0.96	0.97	0.95	0.96	0.97	0.95	0.96	0.97	0.95	0.96	0.97

NOTES:

^a Runoff coefficients for storm recurrence intervals less than 25 years.

^b Runoff coefficients for storm recurrence intervals of 25 years or more.

Source: Rawls, W.J., S.L. Long, and R.H. McCuen, 1981. Comparison of Urban Flood Frequency Procedures. Preliminary Draft Report prepared for the Soil Conservation Service, Beltsville, Maryland.

APPENDIX C, TABLE C-2.a
STORMWATER MANAGEMENT DESIGN CRITERIA

RUNOFF CURVE NUMBERS (FROM NRCS (SCS) TR-55)

Runoff Curve Numbers for Urban Areas						
Cover Description		Curve Numbers for Hydrologic Soil Groups				
Cover Type and Hydrologic Condition	Average Percent Impervious Area	A	B	C	D	
<i>Fully Developed Urban Areas (Vegetation Established)</i>						
Open Space (lawns, parks, golf courses, etc.):						
Poor Condition (grass cover < 50%)		68	79	86	89	
Fair Condition (grass cover 50% to 75%)		49	69	79	84	
Good Condition (grass cover > 75%)		39	61	74	80	
Impervious Areas:						
Paved Parking Lots, Roofs, Driveways, etc.		98	98	98	98	
Streets and Roads:						
Paved: Curbed and Storm Sewers		98	98	98	98	
Paved: Open Ditches		83	89	92	93	
Gravel		76	85	89	91	
Dirt		72	82	87	89	
Urban Districts:						
Commercial and Business		85%	89	92	94	95
Industrial		72%	81	88	91	93
Residential Districts by Average Lot Size:						
1/8 Acres or less		65%	77	85	90	92
1/4 Acre		38%	61	75	83	87
1/3 Acre		30%	57	72	81	86
1/2 Acre		25%	54	70	80	85
1 Acre		20%	51	68	79	84
2 Acres		12%	46	65	77	82

APPENDIX C, TABLE C-2.b
STORMWATER MANAGEMENT DESIGN CRITERIA

RUNOFF CURVE NUMBERS (FROM NRCS (SCS) TR-55)

Runoff Curve Numbers for Cultivated Agricultural Lands						
Cover Description			Curve Numbers for Hydrologic Soil Groups			
Cover Type	Treatment	Hydrologic Condition	A	B	C	D
Fallow	Bare Soil	--	77	86	91	94
	Crop Residue Cover (CR)	Poor	76	85	90	93
		Good	74	83	88	90
Row Crops	Straight Row (SR)	Poor	72	81	88	91
		Good	67	78	85	89
	SR + CR	Poor	71	80	87	90
		Good	64	75	82	85
	Contoured (C)	Poor	70	79	84	88
		Good	65	75	82	86
	C + CR	Poor	69	78	83	87
		Good	64	74	81	85
	Contoured & Terraced (C & T)	Poor	66	74	80	82
		Good	62	71	78	81
C & T + CR	Poor	65	73	79	81	
	Good	61	70	77	80	
Small Grain	SR	Poor	65	76	84	88
		Good	63	75	83	87
	SR + CR	Poor	64	75	83	86
		Good	60	72	80	84
	C	Poor	63	74	82	85
		Good	61	73	81	84
	C + CR	Poor	62	73	81	84
		Good	60	72	80	83
	C & T	Poor	61	72	79	82
		Good	59	70	78	81
C & T + CR	Poor	60	71	78	81	
	Good	58	69	77	80	
Close Seeded or Broadcast Legumes Or Rotation Meadow	SR	Poor	66	77	85	89
		Good	58	72	81	85
	C	Poor	64	75	83	85
		Good	55	69	78	83
	C & T	Poor	63	73	80	83
		Good	51	67	76	80

APPENDIX C, TABLE C-2.c
STORMWATER MANAGEMENT DESIGN CRITERIA

RUNOFF CURVE NUMBERS (FROM NRCS (SCS) TR-55)

Runoff Curve Numbers for Other Agricultural Lands					
Cover Description		Curve Numbers for Hydrologic Soil Groups			
Cover Type	Hydrologic Condition	A	B	C	D
Pasture, Grassland, or Range – Continuous Forage for Grazing	Poor	68	79	86	89
	Fair	49	69	79	84
	Good	39	61	74	80
Meadow – Continuous Grass, Protected from Grazing and Generally Mowed for Hay	--	30	58	71	78
Brush – Brush, Weed, Grass Mixture with brush the major element	Poor	48	67	77	83
	Fair	35	56	70	77
	Good	30	48	65	73
Woods – Grass Combination (orchard or tree farm)	Poor	57	73	82	86
	Fair	43	65	76	82
	Good	32	58	72	79
Woods	Poor	45	66	77	83
	Fair	36	60	73	79
	Good	30	55	70	77
Farmsteads – Buildings, Lanes, Driveways and Surrounding Lots.	--	59	74	82	86

APPENDIX C, TABLE C-3
STORMWATER MANAGEMENT DESIGN CRITERIA
MANNING'S EQUATION "n" ROUGHNESS COEFFICIENTS

Description	Manning's "n"
Smooth-Wall Plastic Pipe	0.011
Concrete Pipe	0.012
Smooth-Lined Corrugated Metal Pipe	0.012
Corrugated Plastic Pipe	0.024
Annular Corrugated Steel and Aluminum Alloy Pipe (Plain or Polymer Coated)	
68 mm x 13 mm (2 2/3 in x 1/2 in) Corrugations	0.024
75 mm x 25 mm (3 in x 1 in) Corrugations	0.027
125 mm x 25 mm (5 in x 1 in) Corrugations	0.025
150 mm x 50 mm (6 in x 2 in) Corrugations	0.033
Helically Corrugated Steel and Aluminum Alloy Pipe (Plain or Polymer Coated)	
75 mm x 25 mm (3 in x 1 in), 125 mm x 25 mm (5 in x 1 in), or 150 mm x 50 mm (6 in x 2 in) Corrugations	0.024
Helically Corrugated Steel And Aluminum Alloy Pipe (Plain or Polymer Coated)	
68 mm x 13 mm (2 2/3 in x 1/2 in) Corrugations	
a. Lower Coefficients*	
450 mm (18 in) Diameter	0.014
600 mm (24 in) Diameter	0.016
900 mm (36 in) Diameter	0.019
1200 mm (48 in) Diameter	0.020
1500 mm (60 in) Diameter or larger	0.021
b. Higher Coefficients**	0.024
Annular or Helically Corrugated Steel or Aluminum Alloy Pipe Arches or Other Non- Circular Metal Conduit (Plain or Polymer Coated)	0.024
Vitrified Clay Pipe	0.012
Ductile Iron Pipe	0.013
Asphalt Pavement	0.015
Concrete Pavement	0.014
Grass Medians	0.050
Grass – Residential	0.030
Earth	0.020
Gravel	0.030
Rock	0.035
Cultivated Areas	0.030 - 0.050
Dense Brush	0.070 - 0.140
Heavy Timber (Little undergrowth)	0.100 - 0.150
Heavy Timber (with underbrush)	0.40
Streams:	
Some Grass and Weeds (Little or no brush)	0.030 - 0.035
Dense Growth of Weeds	0.035 - 0.050
Some Weeds (Heavy brush on banks)	0.050 - 0.070

Notes:

* Use the lower coefficient if any one of the following conditions apply:

- a. A storm pipe longer than 20 diameters, which directly or indirectly connects to an inlet or manhole, located in swales adjacent to shoulders in cut areas, shoulders in cut areas or depressed medians.
- b. A storm pipe which is specially designed to perform under pressure.

** Use the higher coefficient if any one of the following conditions apply:

- a. A storm pipe which directly or indirectly connects to an inlet or manhole located in highway pavement sections or adjacent to curb or concrete median barrier.
- b. A storm pipe which is shorter than 20 diameters long.
- c. A storm pipe which is partly lined helically corrugated metal pipe.

APPENDIX C, TABLE C-4 STORMWATER MANAGEMENT DESIGN CRITERIA

MANNING'S EQUATION "n" ROUGHNESS COEFFICIENTS FOR TR-55 TIME OF CONCENTRATION CALCULATIONS (SHEET FLOW)

Surface Description	Manning's "n"¹
Smooth Surfaces (Concrete, Asphalt, Gravel, or Bare Soil)	0.011
Fallow (No Residue)	0.050
Cultivated Soils:	
Residue Cover (less than or equal to 20%)	0.060
Residue Cover (greater than 20%)	0.170
Grass:	
Short Grass Prairie	0.150
Dense Grasses ²	0.240
Bermudagrass	0.410
Range (Natural)	0.130
Woods: ³	
Light Underbrush	0.400
Dense Underbrush	0.800

Notes:

1. The "n" values are a composite of information compiled by Engman (1986).
2. Includes species such as weeping lovegrass, bluegrass, buffalo grass, blue grama grass, and native grass mixtures.
3. When selecting "n", consider cover to a height of about 0.1 feet. This is the only part of the plant cover that will obstruct sheet flow.

APPENDIX D – STANDARD DETAILS

Table of Contents:

- D-2 Roof Pitch & Downspout Discharge
- D-3 Infiltration Trench
- D-4 Basin Section
- D-5 Typical Building Downspout
- D-6 Trench Backfill
- D-7 Standard Inlet Box
- D-8 Type M Concrete Inlet Top Unit
- D-9 Type C Concrete Inlet Top Unit
- D-10 Bicycle Safe Structural Steel Grate
- D-11 Stormsewer Manhole Cover
- D-12 Type D-W Endwall
- D-13 Headwall Trash Rack
- D-14 Precast Trench Drain

Note:

All details shall be consistent with PennDOT Publication 72M – Standards for Roadway Construction, latest edition.

ROOF PITCH & DOWNSPOUT DISCHARGE

NOT TO SCALE

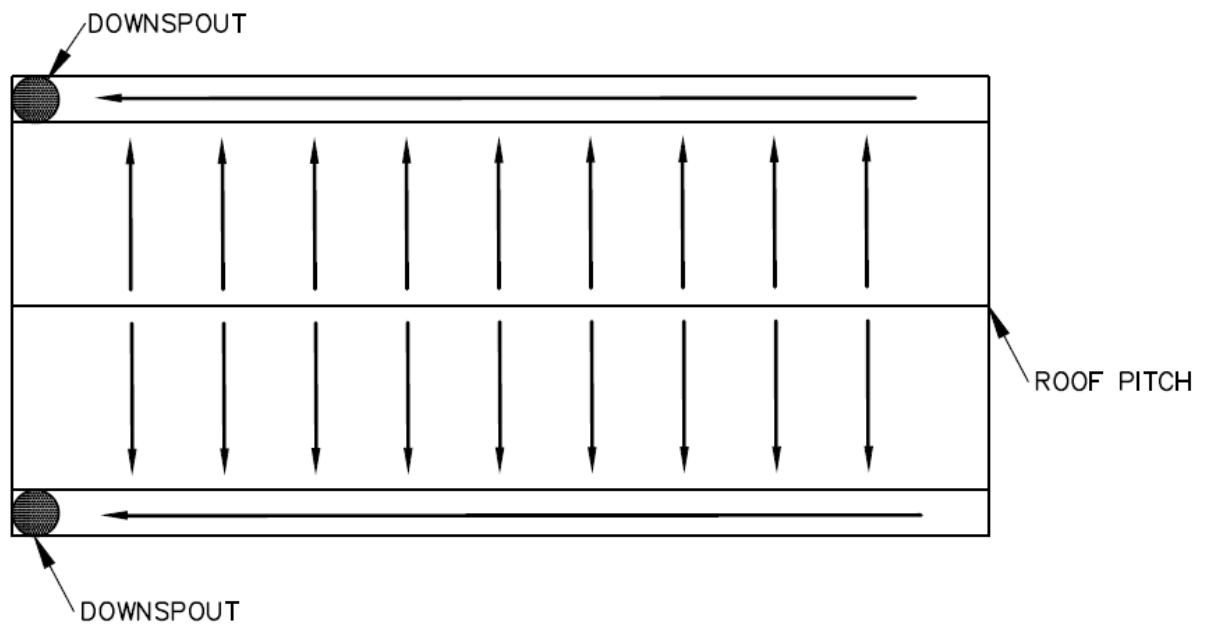

INFILTRATION TRENCH

XW x XL x XH
NOT TO SCALE

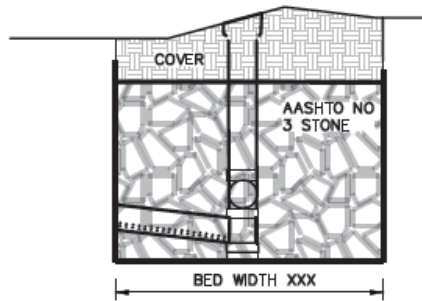
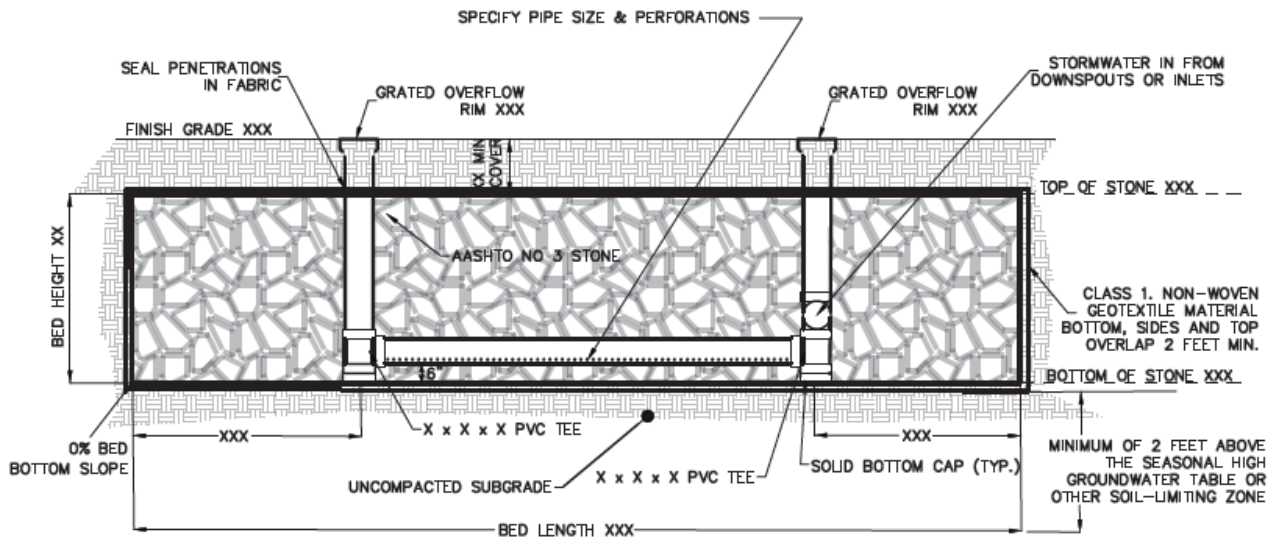

BASIN SECTION

NOT TO SCALE

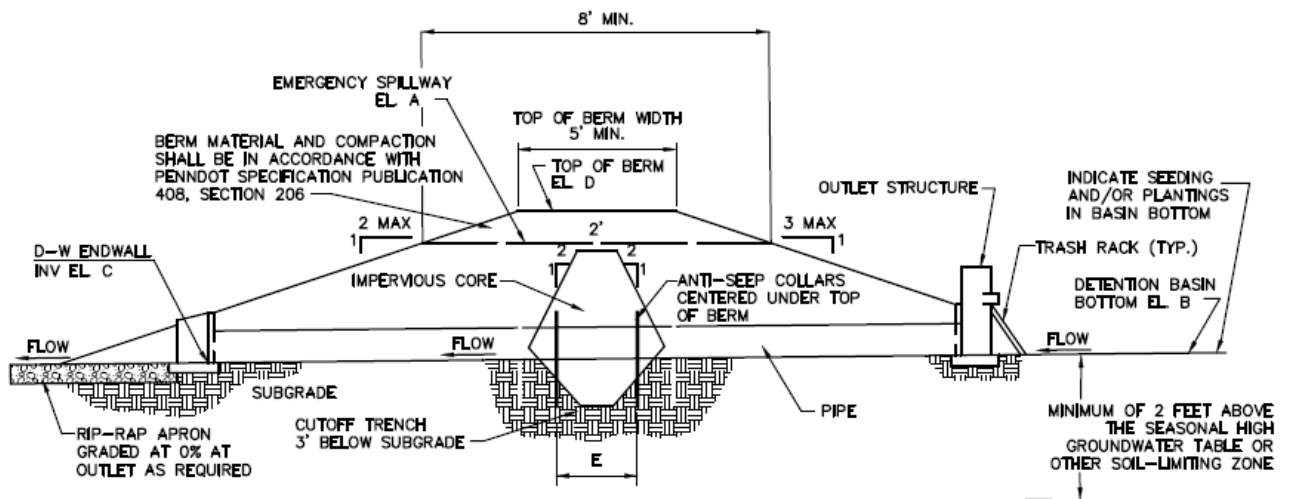

BASIN NO.	A	B	C	D	E	PIPE
X	XXX.XX	XXX.XX	XXX.XX	XXX.XX	XXX.XX	XX', XX:RCP, X.XX%

- NOTES**
1. CORE MATERIAL UNIFIED CLASS, CH OR CL COMPACTED TO 95% OF MAXIMUM DENSITY.
 2. HOMOGENEOUS EMBANKMENT MATERIAL TO BE COMPACTED IN 8" LAYERS TO A MINIMUM FINAL DENSITY OF NOT LESS THAN 95% OF MAX. DRY WEIGHT AT OPTIMUM MOISTURE CONTENT.

TYPICAL BUILDING DOWNSPOUT

NOT TO SCALE

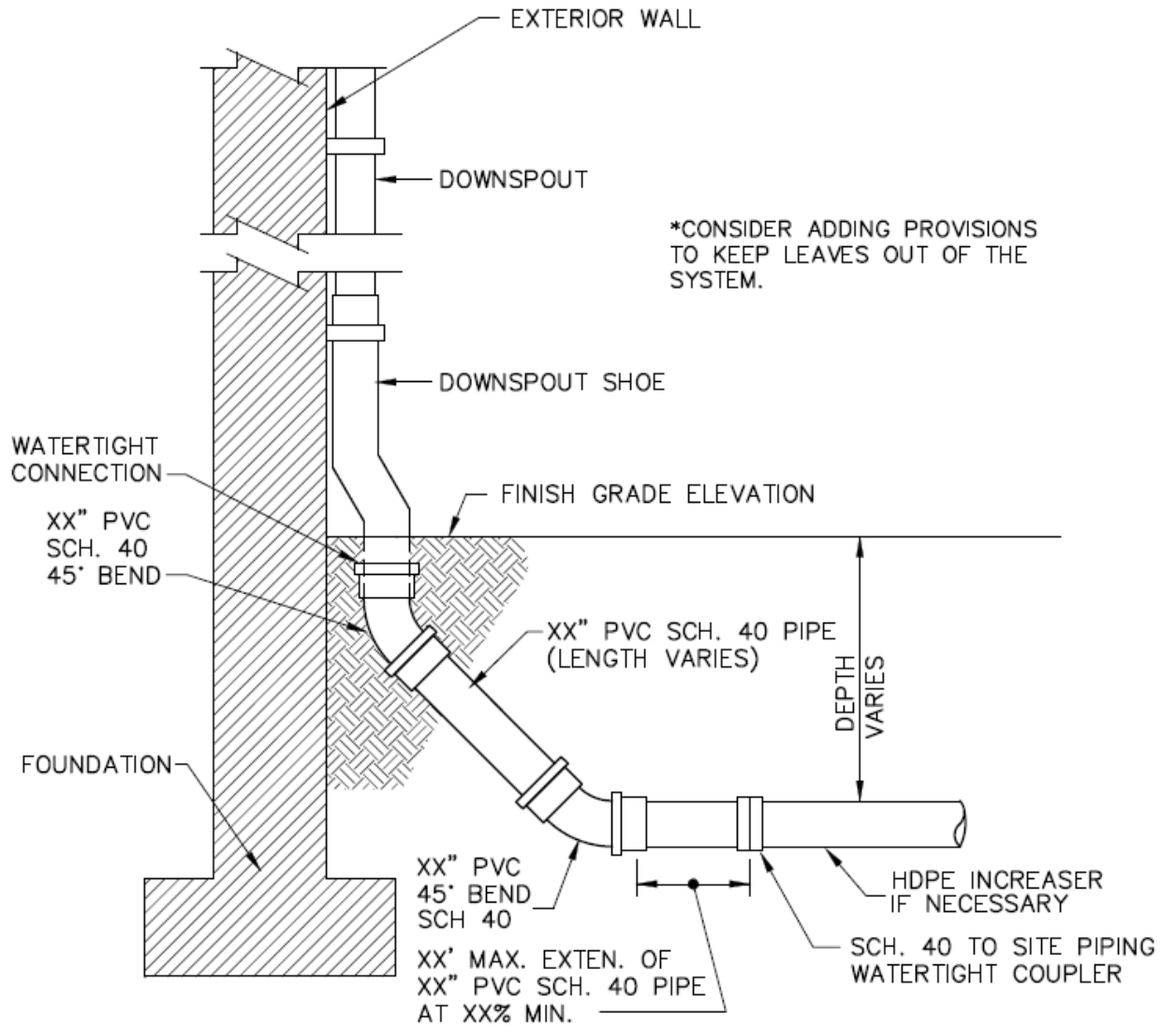

TRENCH BACKFILL

NOT TO SCALE

REFER TO PENNDOT
PUB 72 -- RC-30M

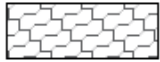

REMOVE ALL LOOSE OR DAMAGED PAVEMENT ALONG THE TRENCH OPENING PRIOR TO PLACEMENT OF A MINIMUM OF 2" OF TEMPORARY SUPERPAVE HMA MATERIAL WHICH SHALL BE MAINTAINED UNTIL FINAL PAVEMENT RESTORATION HAS BEEN COMPLETED.



SAWCUT EXISTING PAVEMENT MINIMUM OF 12" PAST THE EDGE OF THE TEMPORARY/DAMAGED PAVEMENT. REMOVE ALL TEMPORARY RESTORATION MATERIAL AND ALL LOOSE OR DAMAGED PAVEMENT. PERMANENT RESTORATION SHALL BE PERFORMED IN ACCORDANCE WITH THE CORRECT DERRY TOWNSHIP STREET SPECIFICATION.

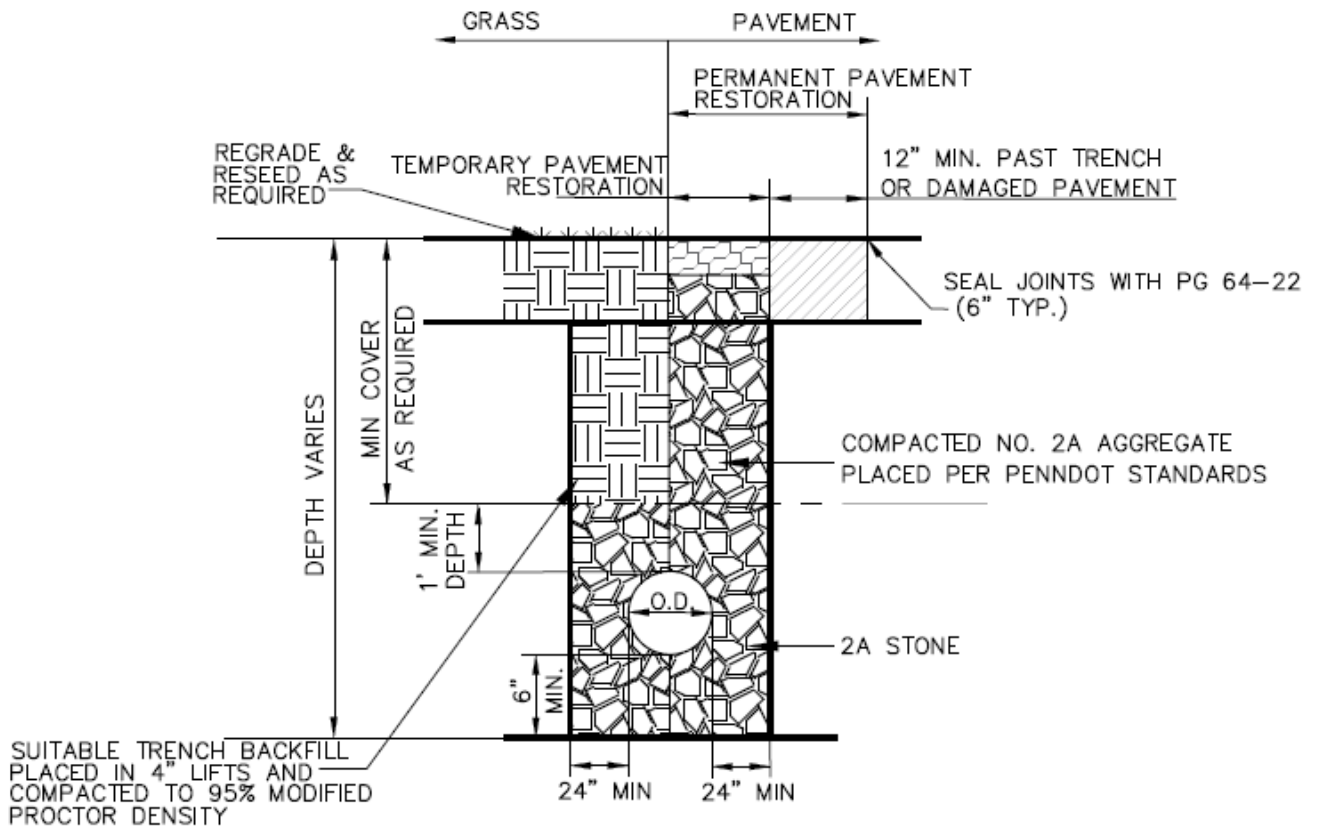

NOTES:

1. COMPACTION TESTS REQUIRED AT THE DISCRETION OF THE TOWNSHIP ENGINEER.
2. STORM TRENCH SHALL BE IN ACCORDANCE WITH RC-30M UNLESS OTHERWISE SPECIFIED.
3. ADDITIONAL CONSIDERATIONS MAY BE REQUIRED BY SITE AND SOIL CONDITIONS OR PIPE MANUFACTURER'S SPECIFICATIONS.

STANDARD INLET BOX

NOT TO SCALE

REFER TO PENNDOT
PUB 72 -- RC-46M

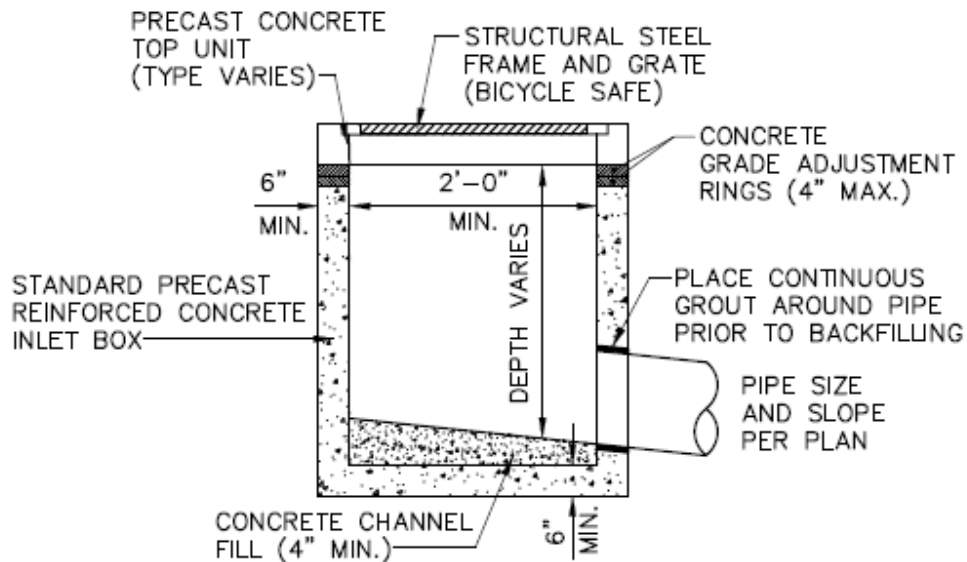
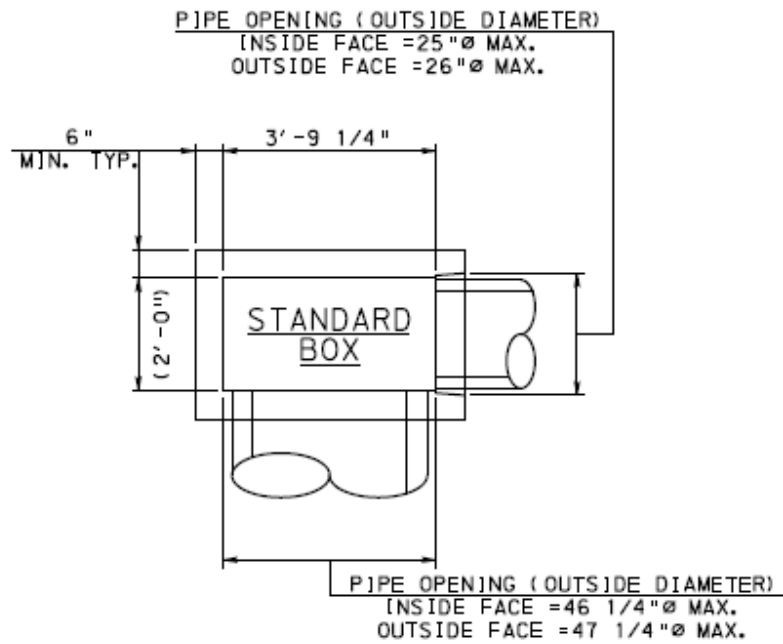

NOTES:

1. CONSTRUCT IN ACCORDANCE WITH PENNDOT PUBLICATION 408, CURRENT EDITION.
2. PROVIDE ALUMINUM STEPS IN INLETS OVER 5' DEEP.

TYPE M CONCRETE INLET TOP UNIT

NOT TO SCALE

REFER TO PENNDOT
PUB 72 -- RC-45M

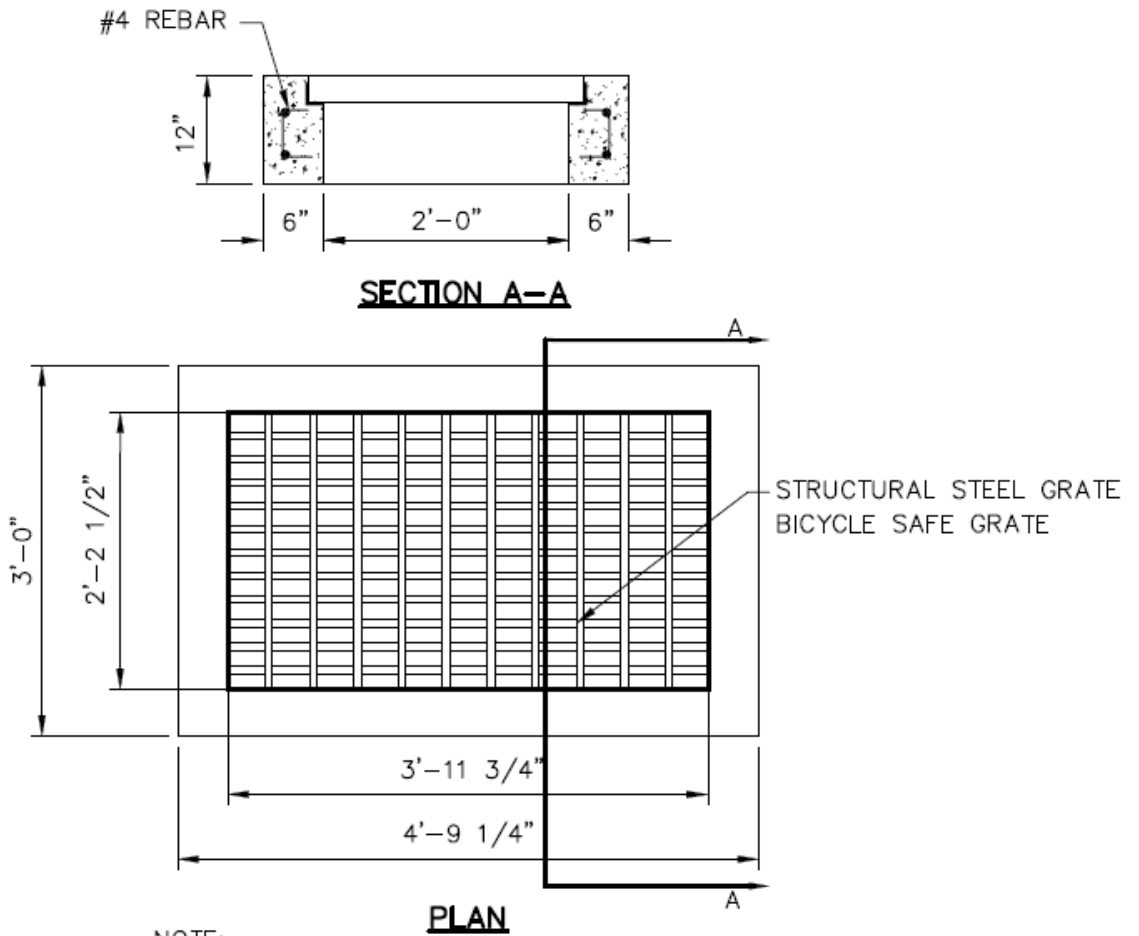

NOTE:
DETAIL SHOWN FOR DIMENSIONAL PURPOSES ONLY.
SEE RC-45M FOR STRUCTURAL REINFORCEMENT.

TYPE C CONCRETE INLET TOP UNIT

NOT TO SCALE

REFER TO PENNDOT
PUB 72 -- RC-45M

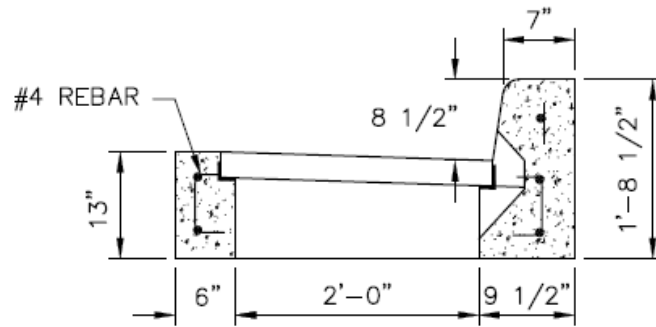

SECTION A-A

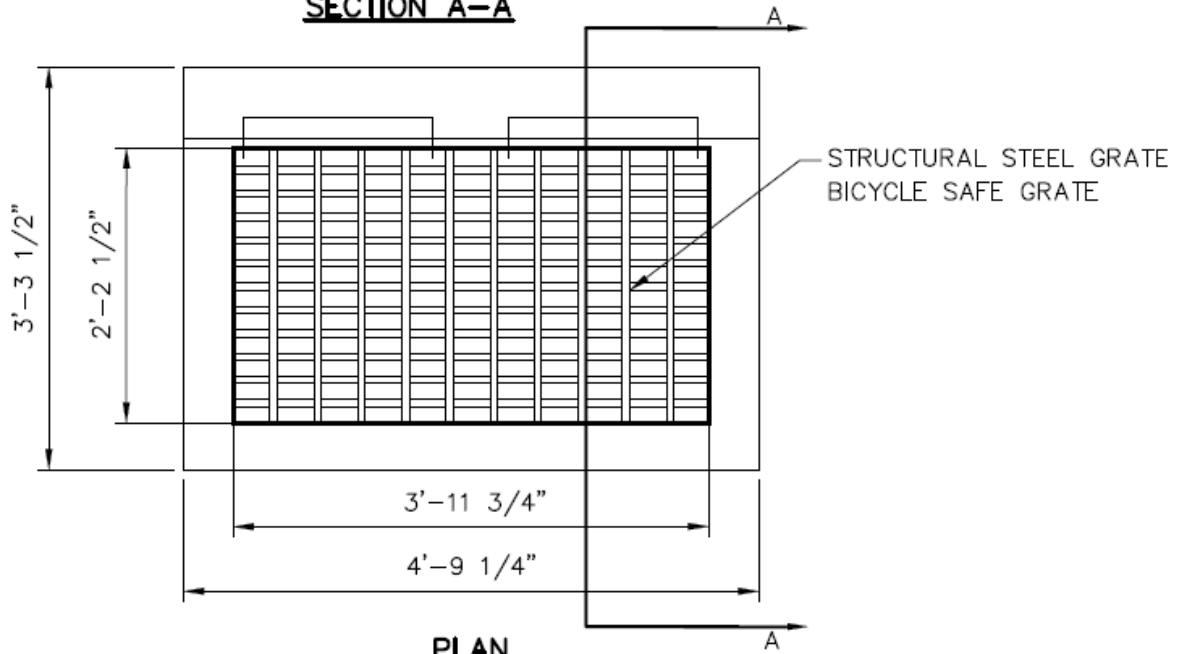

PLAN

NOTE:
DETAIL SHOWN FOR DIMENSIONAL PURPOSES ONLY.
SEE RC-45M FOR STRUCTURAL REINFORCEMENT.

BICYCLE SAFE STRUCTURAL STEEL GRATE

NOT TO SCALE

REFER TO PENNDOT
PUB 72 -- RC-45M

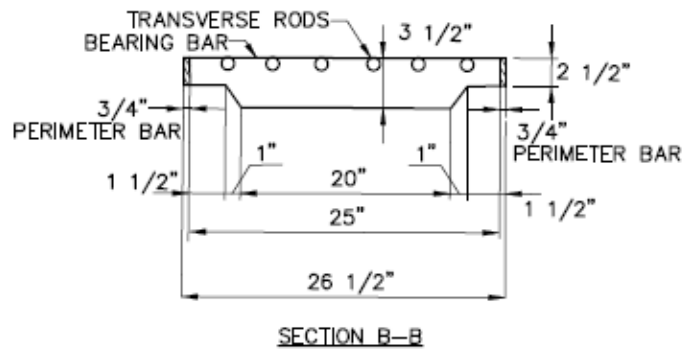
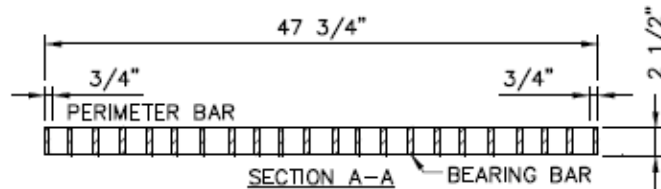
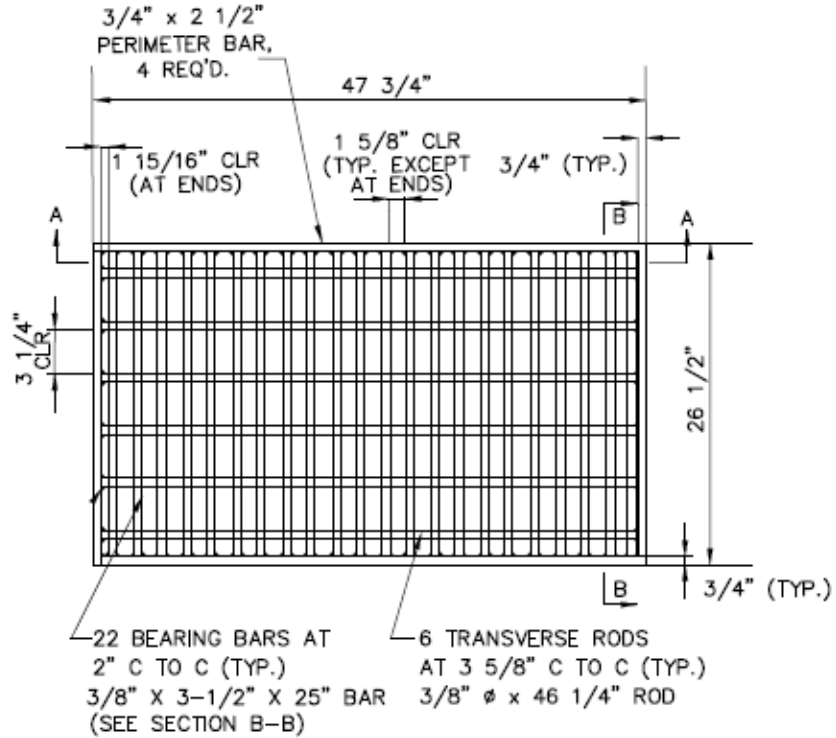

STORM SEWER MANHOLE

NOT TO SCALE

REFER TO PENNDOT
PUB 72 -- RC-39M

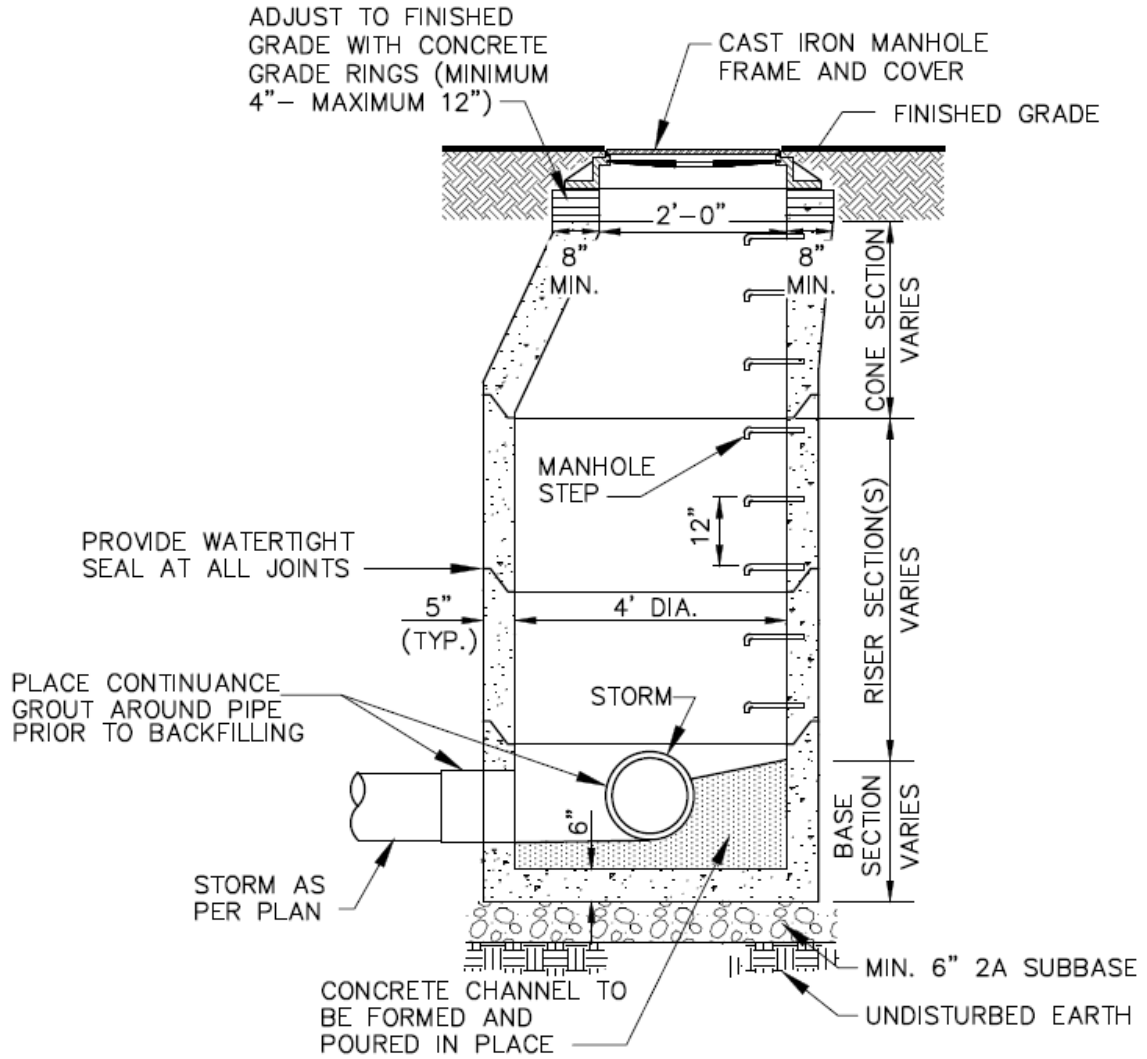

STORM SEWER MANHOLE COVER

NOT TO SCALE

REFER TO PENNDOT
PUB 72 -- RC-39M

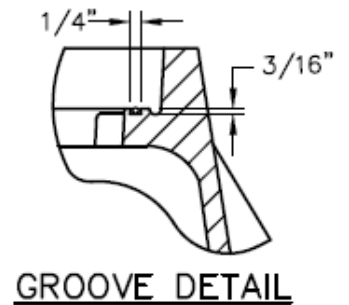
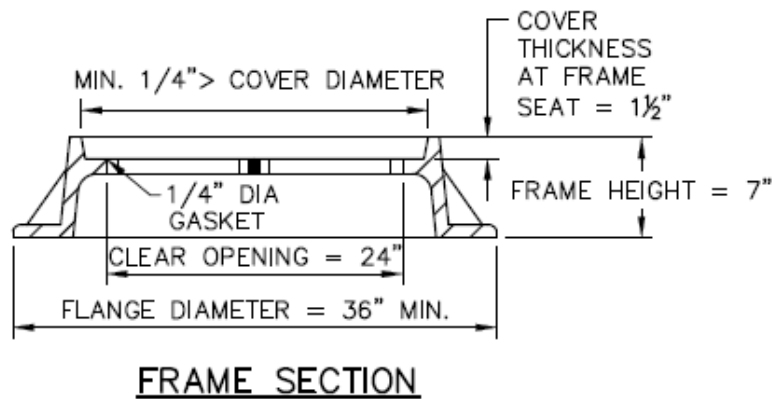
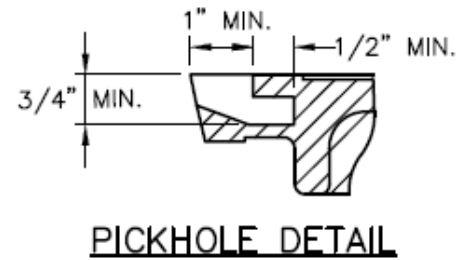
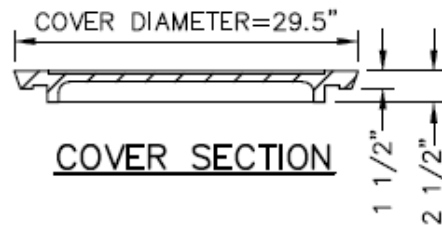
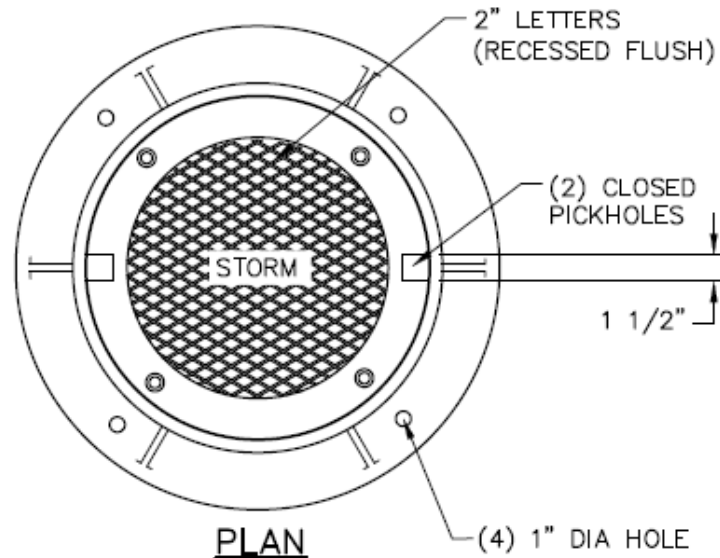

NOTE: MINIMUM H-25 LOAD RATING

TYPE D-W ENDWALL

NOT TO SCALE

REFER TO PENNDOT
PUB 72 -- RC-31M

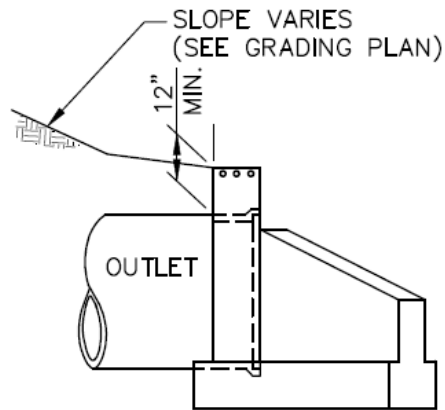

SIDE ELEVATION

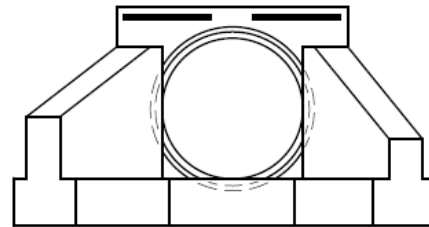

FRONT ELEVATION

NOTES:

1. CONSTRUCT IN ACCORDANCE WITH PENNDOT PUBLICATION 72 RC-31, CURRENT EDITION, OR PUB 218 BD-631 AS DETERMINED BY PIPE SIZE.

HEADWALL TRASH RACK

NOT TO SCALE

3/8" DIA., 5" LONG STAINLESS
STEEL ANCHOR BOLTS WITH GROUT (TYP.)
MINIMUM 4 BOLTS ON TOP, 5 ON BOTTOM
AND 4 ON EACH SIDE ANGLE

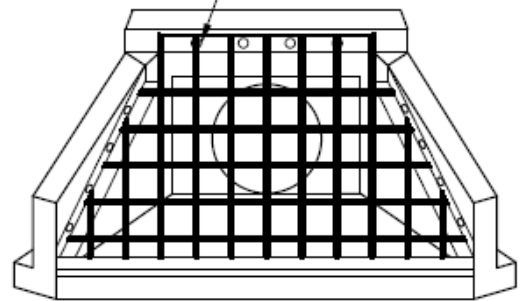

ISOMETRIC

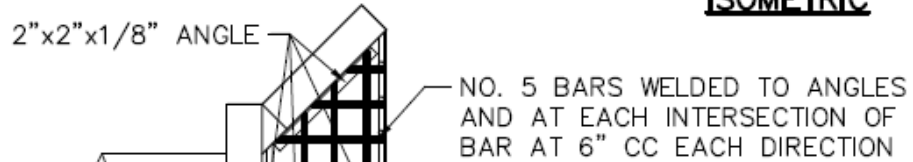

PROVIDE GAL. HINGE ACROSS
ENTIRE TOP LENGTH: ATTACH
W/ (4) 1/2" DIA, A-307 2" GAL
MACH. BOLTS

PLAN

WELD BARS TO HINGE
AND ANGLE AS SHOWN

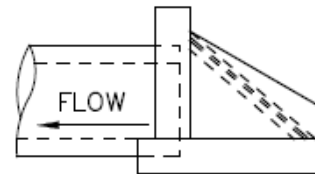

SECTION

NOTES:

1. TRASH RACK SHALL BE REMOVABLE FOR CLEANING.
2. GALVANIZED PAINT SHALL BE APPLIED TO ENTIRE TRASH RACK AFTER WELDING.
3. DIMENSION APPROPRIATELY FOR HEADWALL UTILIZED.

APPENDIX E

SPRING CREEK WATERSHED RELEASE RATES

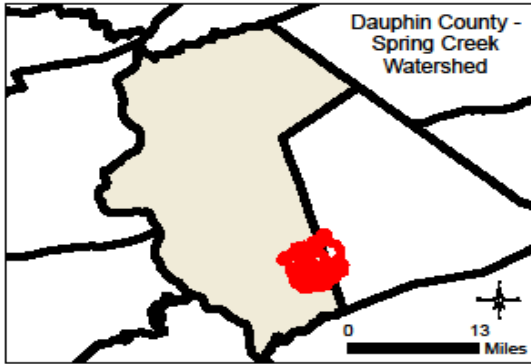

Spring Creek Watershed Release Rates

Subwatershed	1 Year	2 Year	10 Year	25 Year	50 Year	100 Year
SP1	100%	90%	90%	90%	100%	100%
SP2	100%	90%	90%	90%	100%	100%
SP3	100%	85%	85%	90%	100%	100%
SP4	100%	90%	90%	90%	100%	100%
SP5	100%	90%	90%	90%	100%	100%
SP6	100%	70%	75%	70%	100%	100%
SP7	100%	90%	90%	90%	100%	100%
SP8	100%	90%	80%	85%	100%	100%
SP9	100%	90%	90%	90%	100%	100%
SP10	100%	85%	90%	90%	100%	100%
SP11	100%	70%	70%	70%	100%	100%
SP12	100%	70%	70%	70%	100%	100%
SP13	100%	70%	70%	70%	100%	100%
SP14	100%	70%	70%	70%	100%	100%
SP15	100%	70%	70%	70%	100%	100%

- Roads
- Railroads
- Streams
- Rivers, Lakes, and Ponds
- Spring Creek Subwatersheds
- County Boundary
- HMS Junctions

APPENDIX F

Standard Stormwater BMP Notes

1. All inlets in paved areas shall have heavy duty bicycle-safe grating consistent with the latest edition of PennDOT Publication 72M.
2. Inlets must be sized to accept the specified pipe sizes without knocking out any of the inlet corners.
3. All pipes entering or exiting inlets shall be cut flush with the inlet wall.
4. Inlets shall not have a sump condition in the bottom (unless designed as a water quality BMP). Outlet pipes shall be flush with the bottom of the box or concrete channels shall be poured.
5. Inlets, manholes, pipes, and culverts shall be constructed in accordance with the specifications set forth in PennDOT's Publication 408, latest edition, and as detailed in PennDOT's Publication 72M - Standards for Roadway Construction (RC), latest edition, or as approved by the Township Engineer.
6. All frames, concrete top units, and grade adjustment rings shall be set in a bed of full mortar according to Publication 408, latest edition.
7. The Stormwater Operation and Maintenance Agreement and Access Easement for this project is to be considered a part of this plan whether or not it appears hereon.
8. The Stormwater Management Report is considered to be a binding document of this plan.
9. An as-built drawing shall be provided for all stormwater management facilities prior to occupancy of the land or structures, or the release of financial security for said facilities. (*This note is only applicable for regulated activities exceeding 5,000 square feet of new impervious area.*)
10. Township officials and their agents or employees have the right of access to the property from the public right-of-way for inspection of and, in cases of construction default, construction of the stormwater management facilities.
11. Nothing shall be placed, planted, or set within an easement or right-of-way that will adversely affect the function of the easement or right-of-way or that will conflict with any conditions associated with such easement or right-of-way.
12. No person shall modify, remove, fill, landscape, or alter any existing stormwater BMP, facilities, areas, or structures without the written approval of the Township and/or DTMA, unless it is part of an approved maintenance program.
13. No person shall place any structure, fill, landscaping, or vegetation into a stormwater BMP, facilities, areas, structures, or within a drainage easement that would limit or alter the functioning of the BMP without the written approval of the Township.

14. The owner of each lot that contains a stormwater BMP shall be responsible for the continued functionality and required maintenance of the facility. (*This note shall be adapted to the conditions of the plan.*)
15. The approved SWM Site Plan shall be on file at the project site throughout the duration of the construction activity.
16. The contractor shall be responsible to remove any debris and flush out all existing and newly constructed storm drainage facilities within the project limits at the completion of construction.

APPENDIX G

STANDARD PLAN CERTIFICATIONS

Qualified Design Professional

I, _____, hereby certify that the Stormwater Management Site Plan meets all design standards and criteria of the Township of Derry Stormwater Management Ordinance, Chapter 174.

By: _____ (seal)

.....
Landowner

I, _____, hereby acknowledge that the stormwater BMPs are fixtures that cannot be altered or removed without prior approval by the Township.

In the event that a claim is asserted against the Township, its designated representatives, or employees, the Township shall promptly notify the Landowner and the Landowner shall defend, at his own expense, any suit based on the claim. If any judgment or claims against the Township's employees or designated representatives shall be allowed, the Landowner shall pay all costs and expenses regarding said judgment or claim.

By: _____
(Owner)

.....

As-Built Plan Certification

I, _____, hereby certify that all permanent stormwater BMPs have been constructed in a manner consistent with the intended function of their design in accordance with the design standards and criteria of the Township of Derry Stormwater Management Ordinance, Chapter 174 and are in accordance with the approved Stormwater Management Site Plan and Report.

All deviations are noted as follows:

-

By: _____

(seal)

